

Pre-Algebra

Date _____ Period _____

Evaluate each expression.

1) $1\frac{1}{2} - \left(-3\frac{1}{6}\right) - \left(-\frac{3}{4}\right) + 1$

2) $1\frac{5}{8} - \left(-\frac{3}{2}\right) - 2\frac{1}{5} - \frac{1}{3}$

Find each product.

3) $-5\frac{6}{7} \times 1\frac{3}{8} \times -\frac{7}{4}$

4) $1\frac{5}{6} \times \frac{5}{7} \times -\frac{3}{2}$

Find each quotient.

5) $5\frac{7}{8} \div 4\frac{1}{2}$

6) $4\frac{1}{3} \div 2\frac{4}{5}$

Evaluate each expression.

7) $2 + \frac{1}{3}\left(\frac{7}{4} + \frac{1}{2}\right)$

8) $1\frac{3}{4} + \frac{6}{5} \div \left(3\frac{4}{5} + 1\frac{3}{4}\right)$

9) $\frac{3}{4} + \frac{3}{5} \div 4\frac{5}{6} + 1$

10) $\frac{4}{3} \div \left(3\frac{1}{3}\right)^2 + 2\frac{1}{2}$

Sketch the graph of each line.

11) $y = 5x - 5$

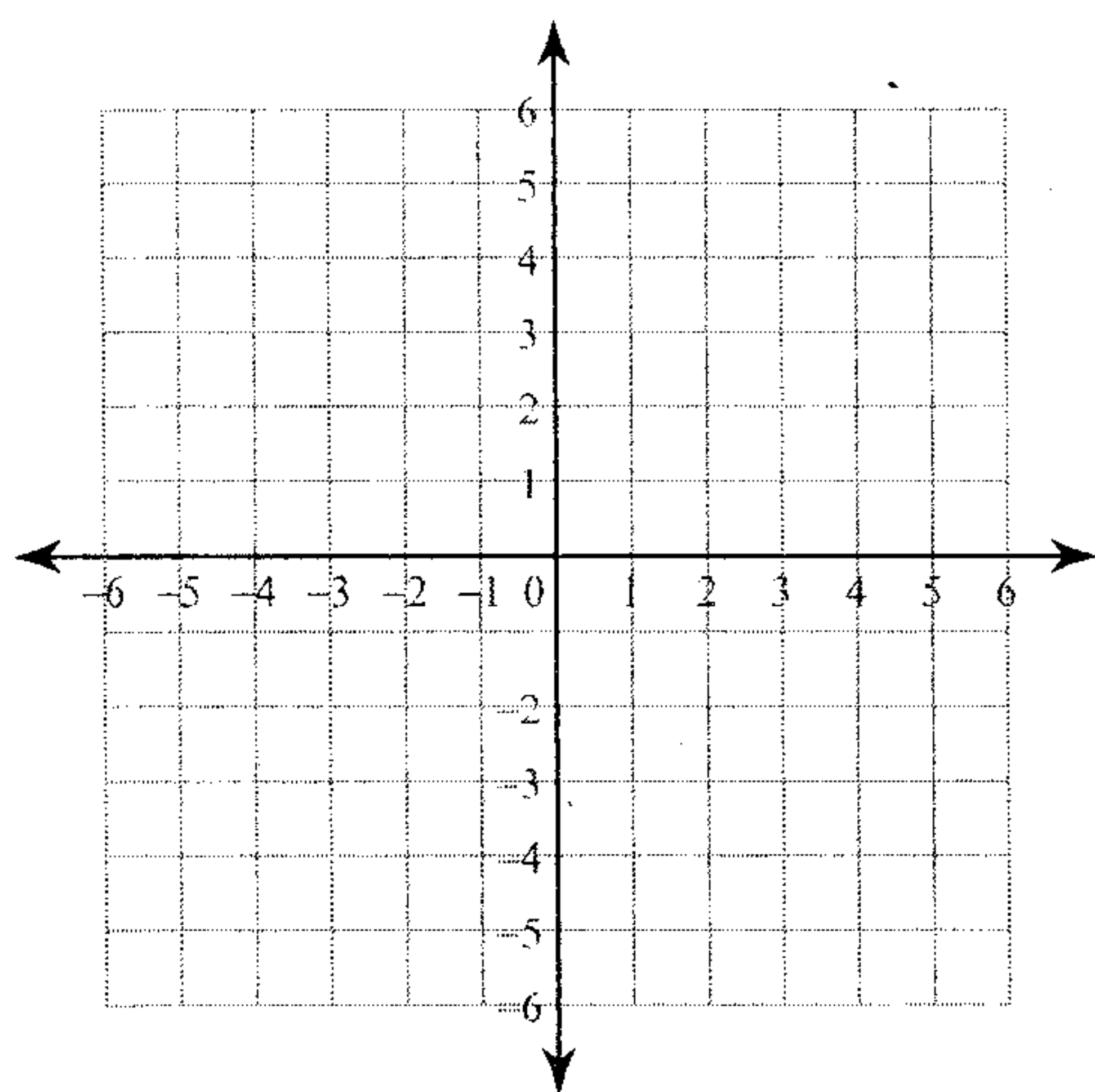

12) $4x - 5y = 15$

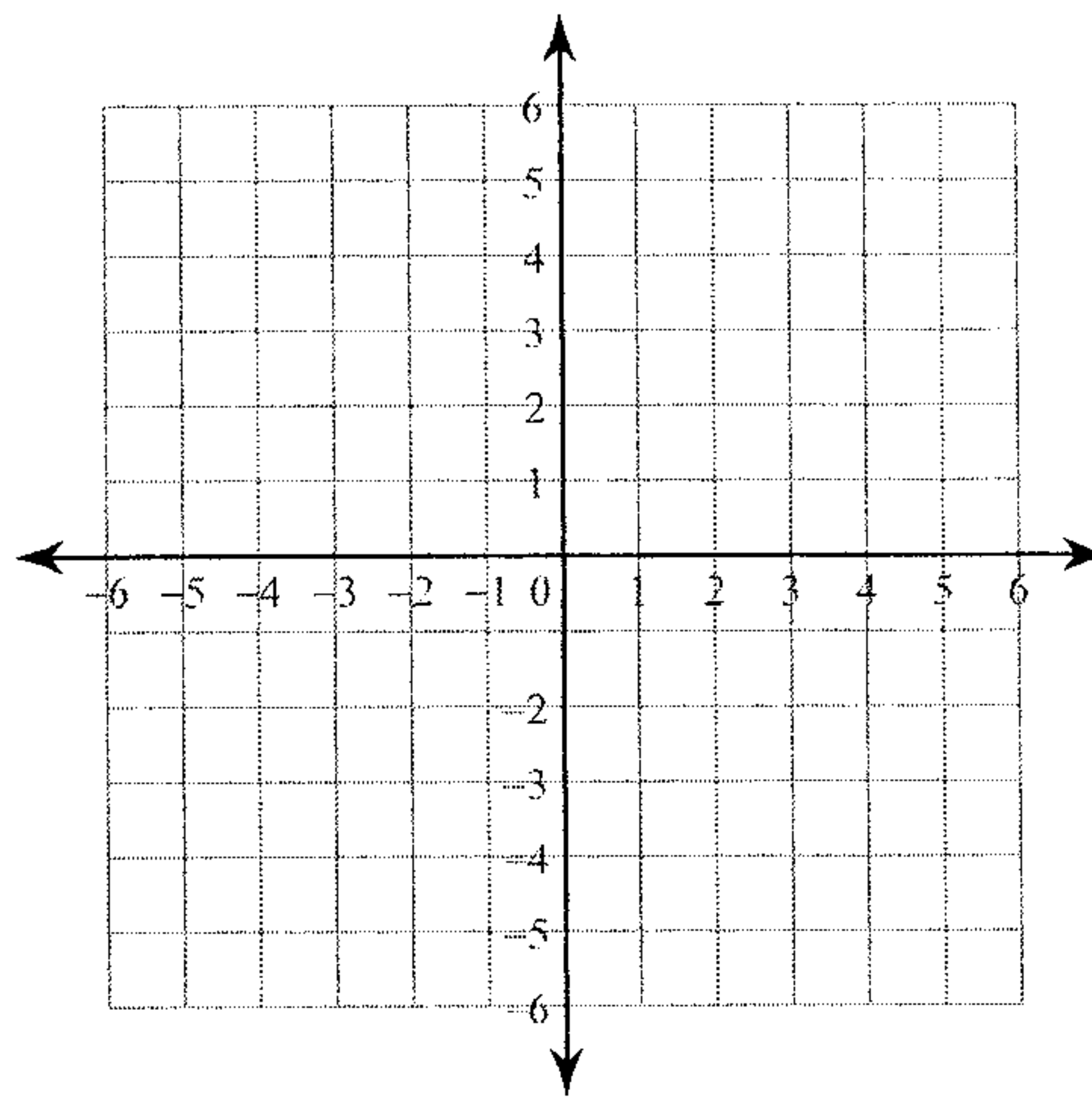

Find the GCF of each.

13) $24y^2x, 32yx$

14) $24a^2b, 18ab$

15) $14a, 36ba, 46a$

16) $16x^2y^2, 16xy, 48x^3y$

Find the LCM of each.

17) $18m^3, 36nm^2$

18) $35, 40x$

19) $16n^2, 24n^2, 40n^4$

20) $40y^3x, 40x^3y, 24x^3y$

Simplify each expression.

21) $(-3p^5 - 12p^4 + 13) - (8p^5 - 6 + 13p^4)$

22) $(8k^5 - 5k^3 + 3k^2) - (8k^3 + 9k^2 + 2k^5)$

Find the distance between each pair of points.

23) $(-6, 7), (1, 5)$

24) $(-2, -5), (-2, 4)$

Simplify each expression.

25) $4x(-3 + x) + 3x(x + 1)$

26) $5(7n - 6) + 4(1 - 3n)$

27) If the weight of a package is multiplied by $\frac{5}{6}$ the result is 46 pounds. Find the weight of the package.

28) Your father gave you \$20.23 with which to buy a present. This covered $\frac{7}{8}$ of the cost. How much did the present cost?

29) Heather won 41 pieces of gum playing horseshoes at the county fair. At school she gave two to every student in her math class. She only has 9 remaining. How many students are in her class?

30) Kristin spent half of her weekly allowance at the movies. To earn more money her parents let her wash the car for \$6.80. What is her weekly allowance if she ended with \$16.50?

Solve each equation.

31) $\frac{r}{-2} - 19 = -8$

32) $\frac{x}{21} + 13 = 12$

Sketch the graph of each linear inequality.

33) $x + 4y < 20$

34) $x - 2y > 10$

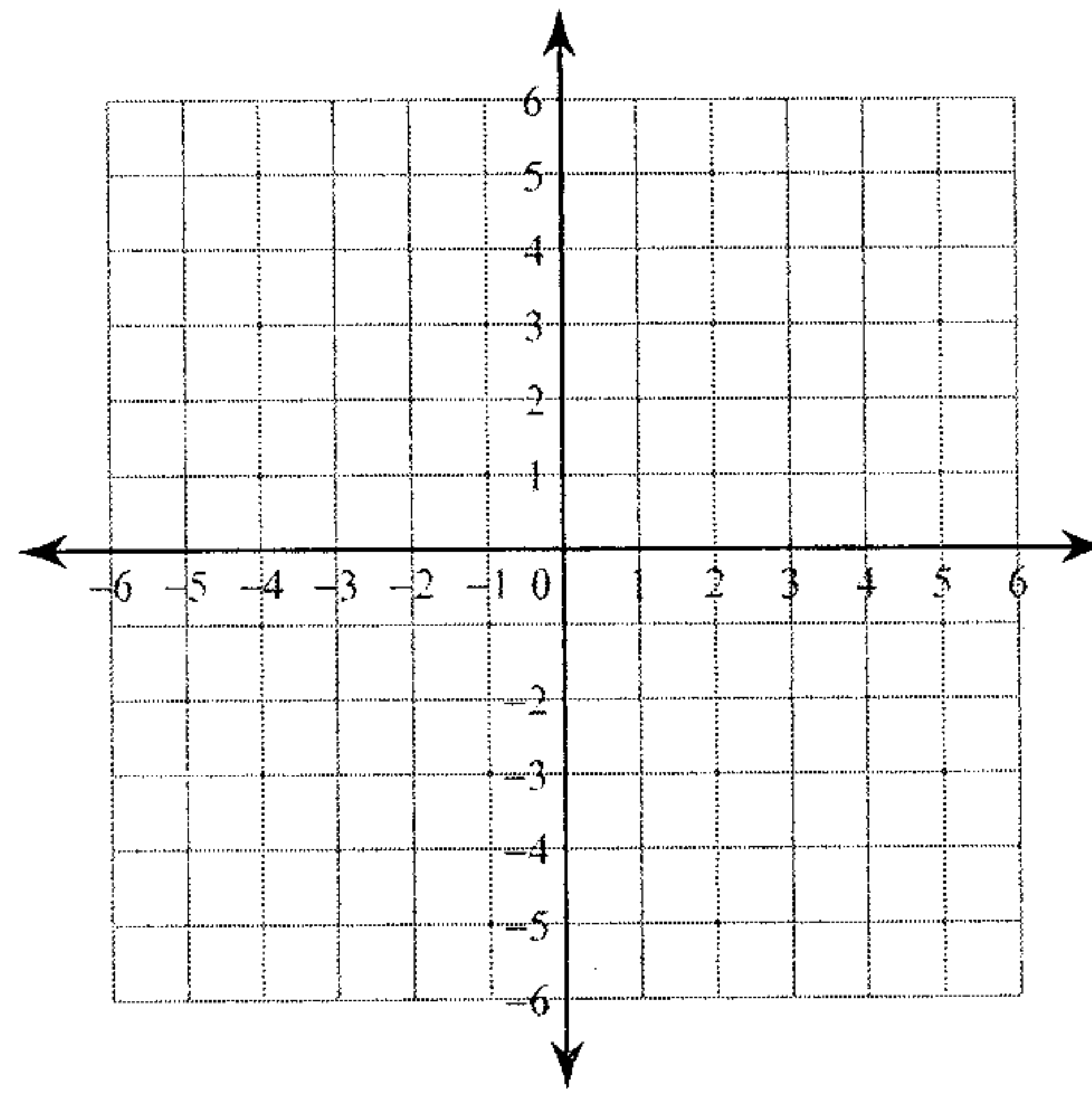
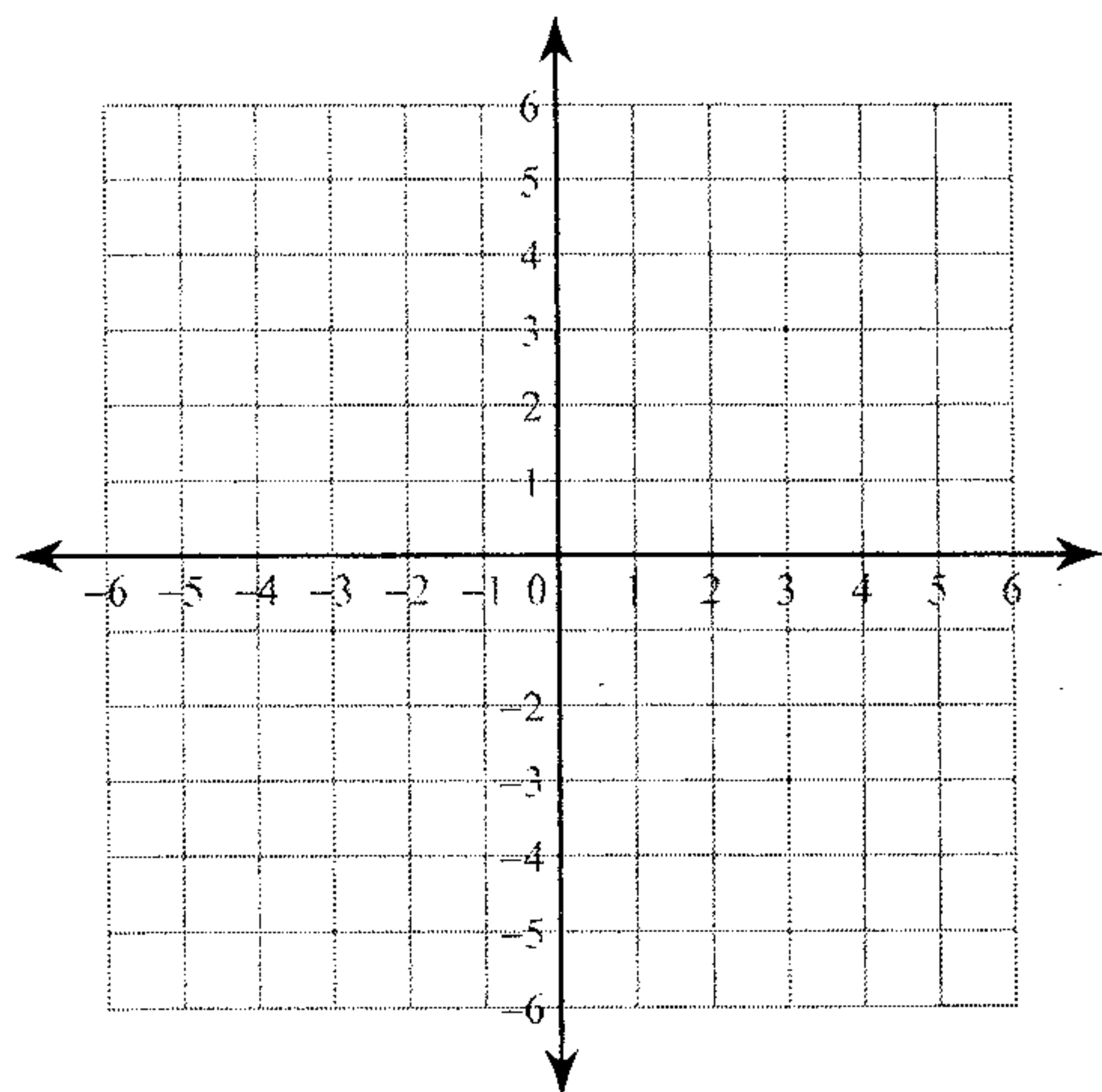

Find the midpoint of the line segment with the given endpoints.

35) $(11, -2), (-8, 11)$

36) $(-11, -4), (-12, 6)$

Find each product.

37) $(-5x - 1)(3x + 8)$

38) $(-n + 5)(-n + 7)$

Find each missing length to the nearest tenth.

39)

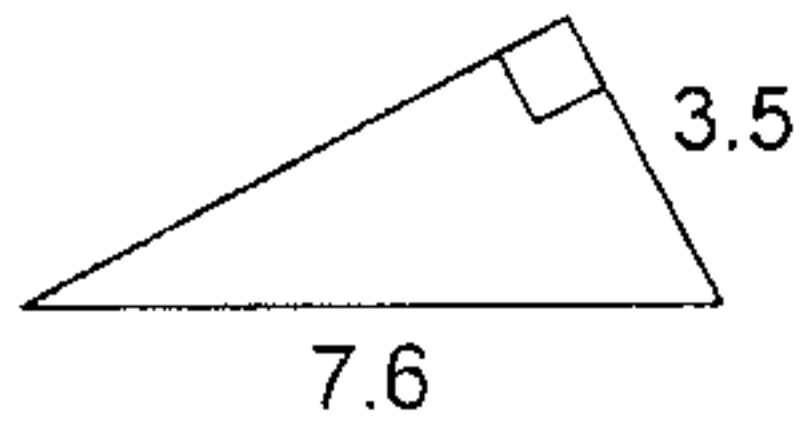

40)

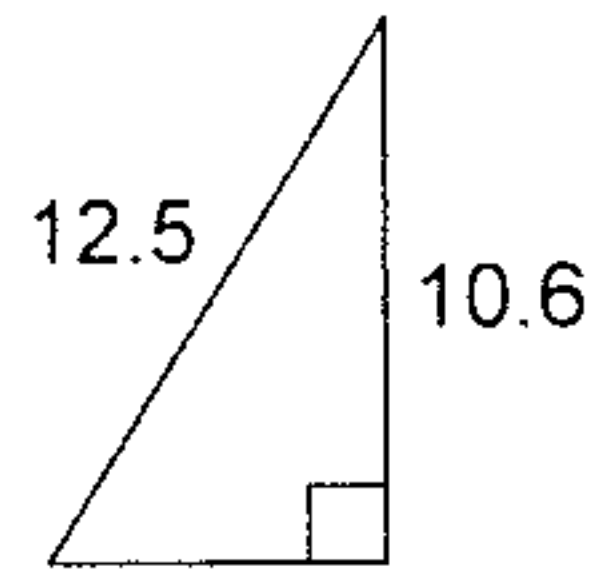

Write each number in scientific notation.

41) 0.000000544

42) 1800

Simplify each expression.

43) $-6(8b - 1) - 2(2b + 5)$

44) $-8v(8 - 7v) + 7v(1 + 3v)$

Find the slope of the line through each pair of points.

45) $(2, 20), (-4, -4)$

46) $(-11, 8), (-13, 11)$

Write the slope-intercept form of the equation of each line.

47)

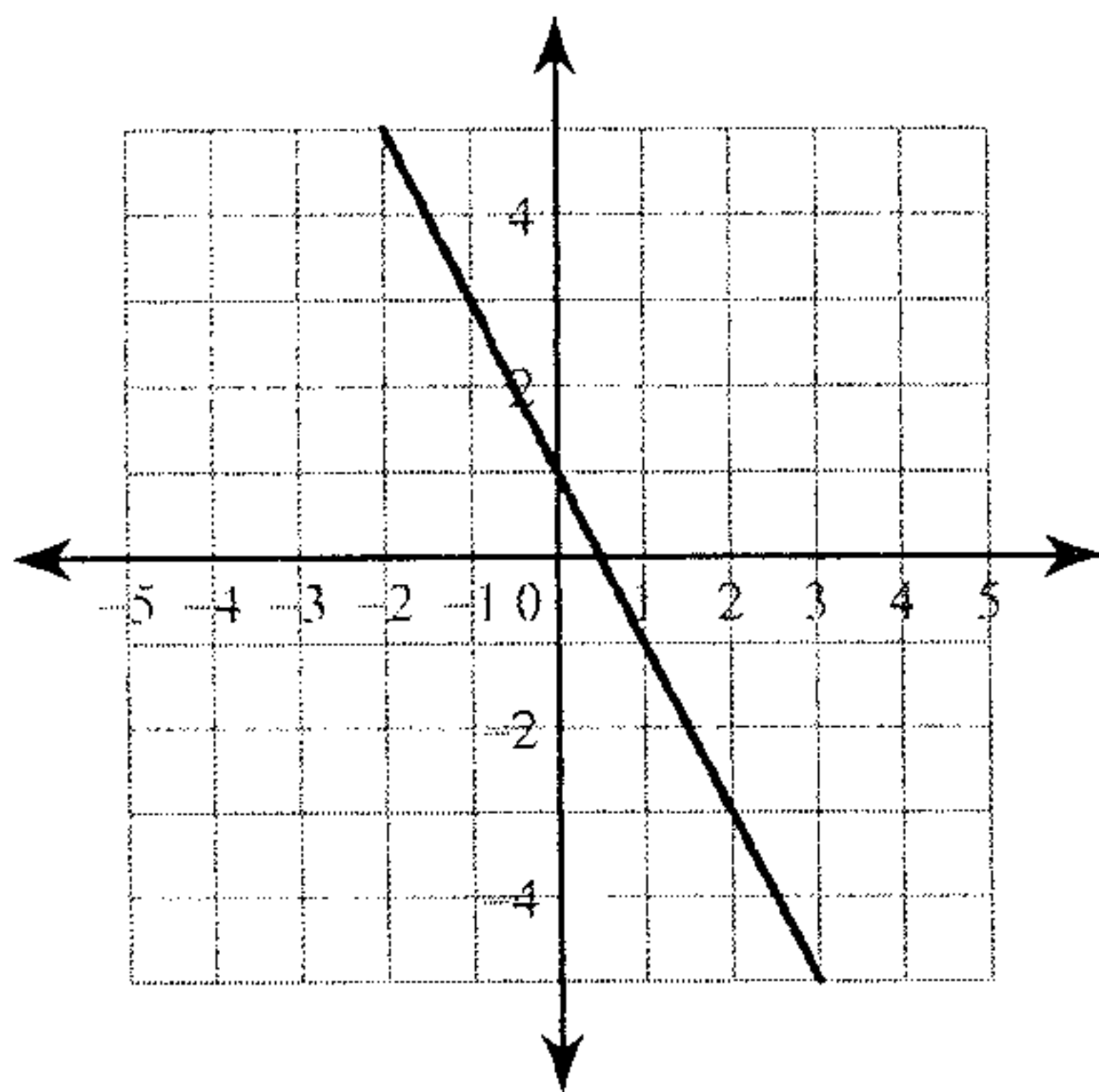

48)

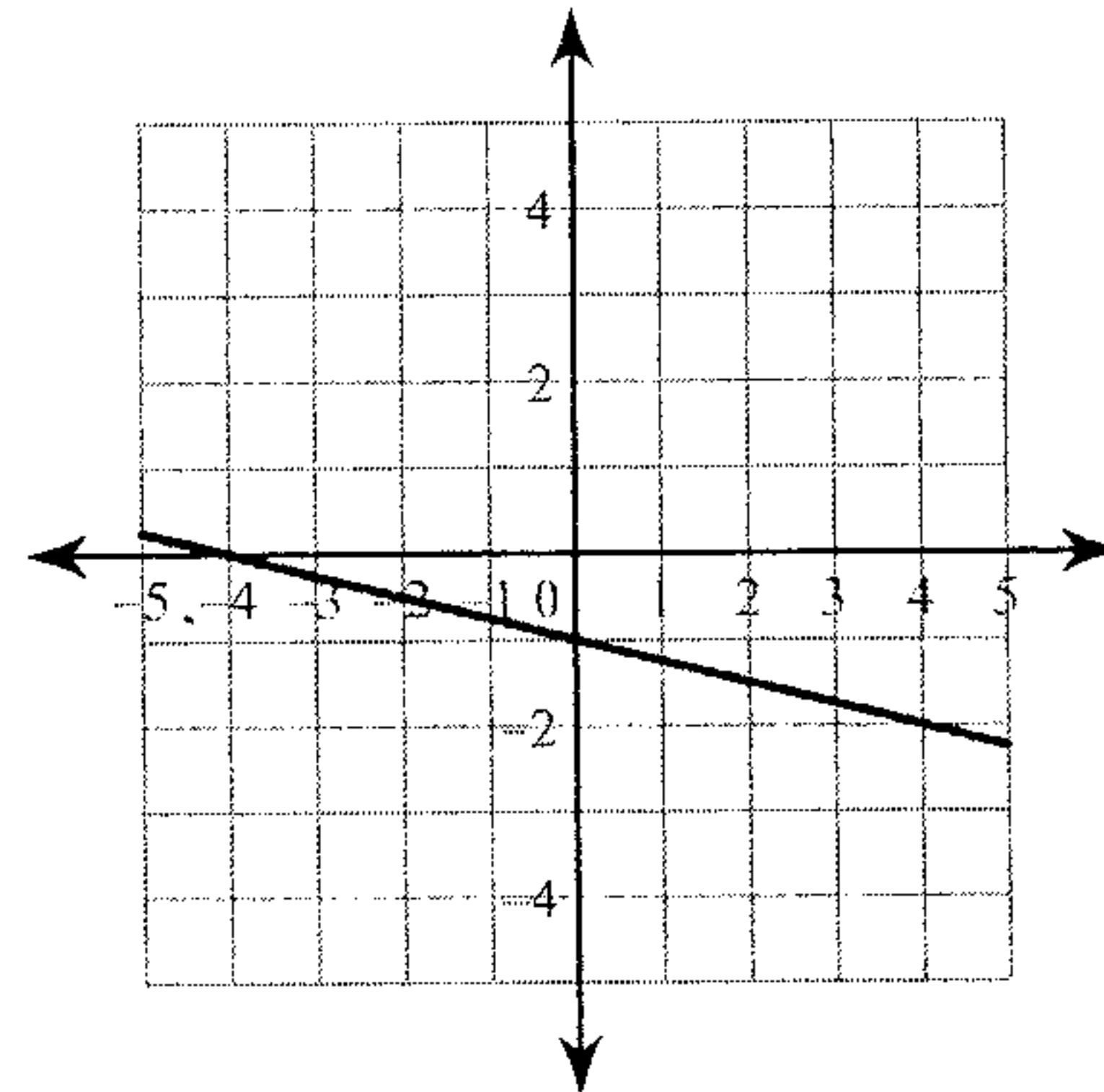

Write the standard form of the equation of each line.

49)

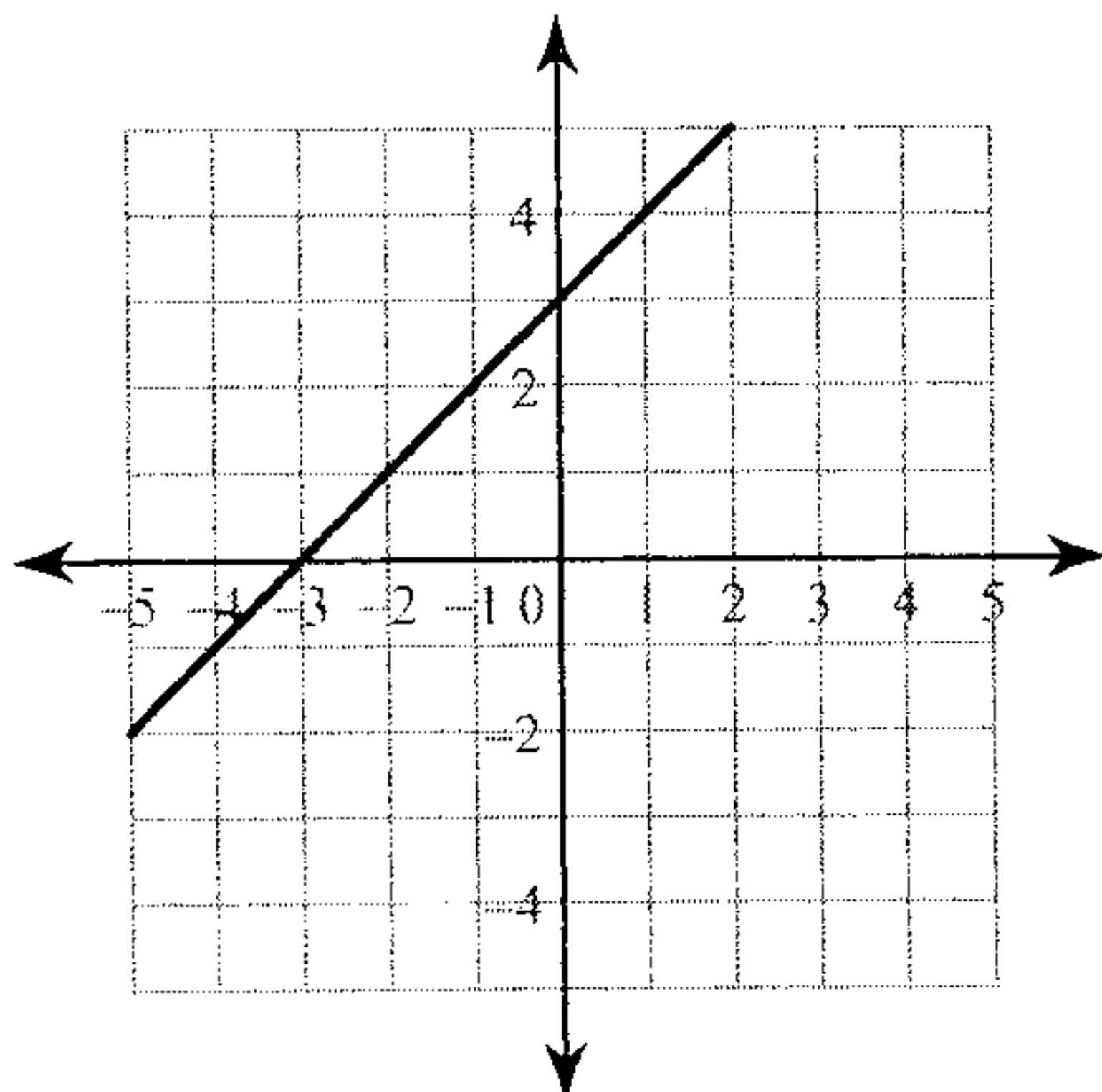

50)

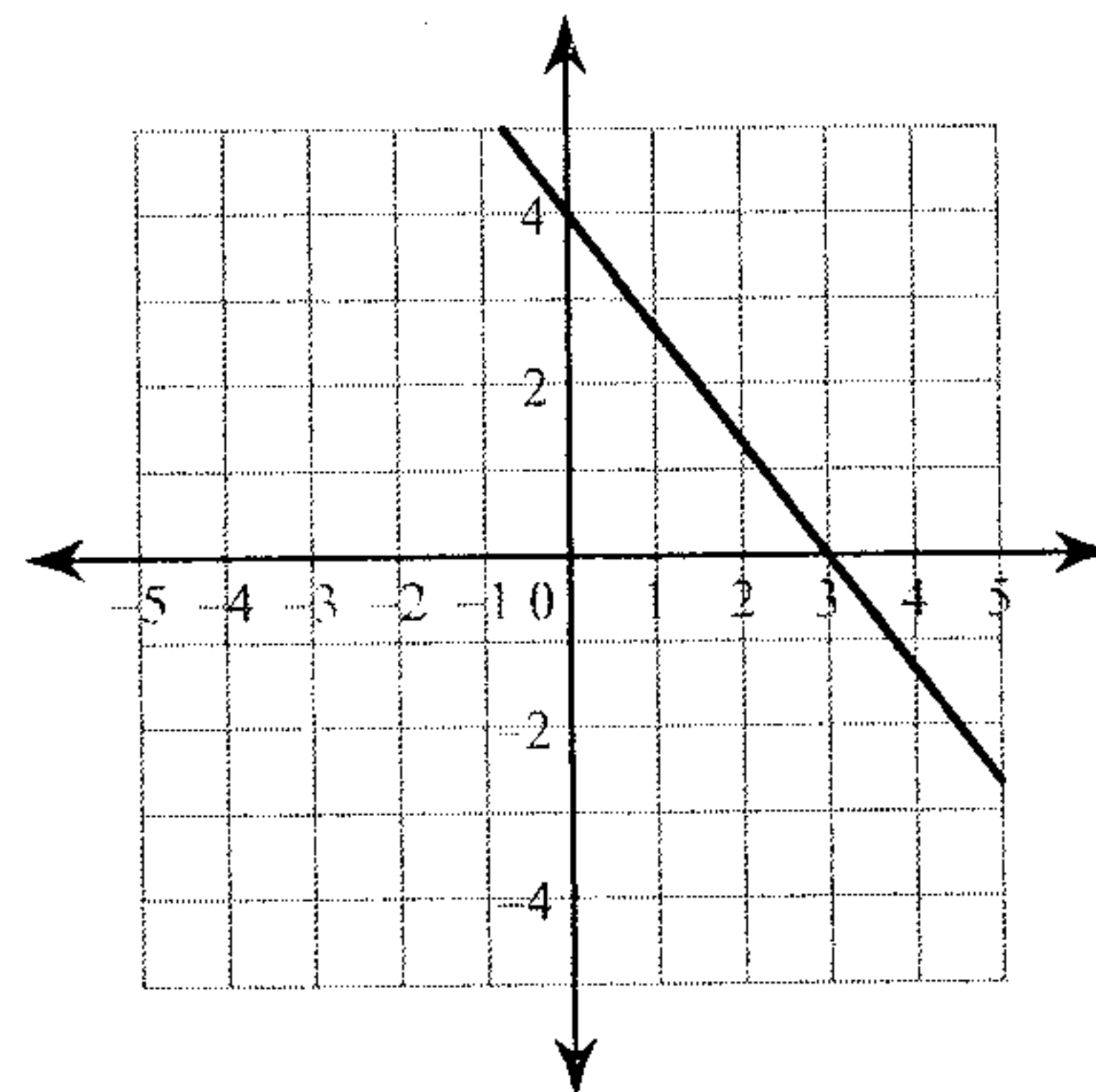

Answers to Pre-Algebra (ID: 1)

1) $6\frac{5}{12}$

2) $\frac{71}{120}$

3) $14\frac{3}{32}$

4) $-1\frac{27}{28}$

5) $1\frac{11}{36}$

6) $1\frac{23}{42}$

7) $2\frac{3}{4}$

8) $1\frac{143}{148}$

9) $1\frac{507}{580}$

10) $2\frac{31}{50}$

11)

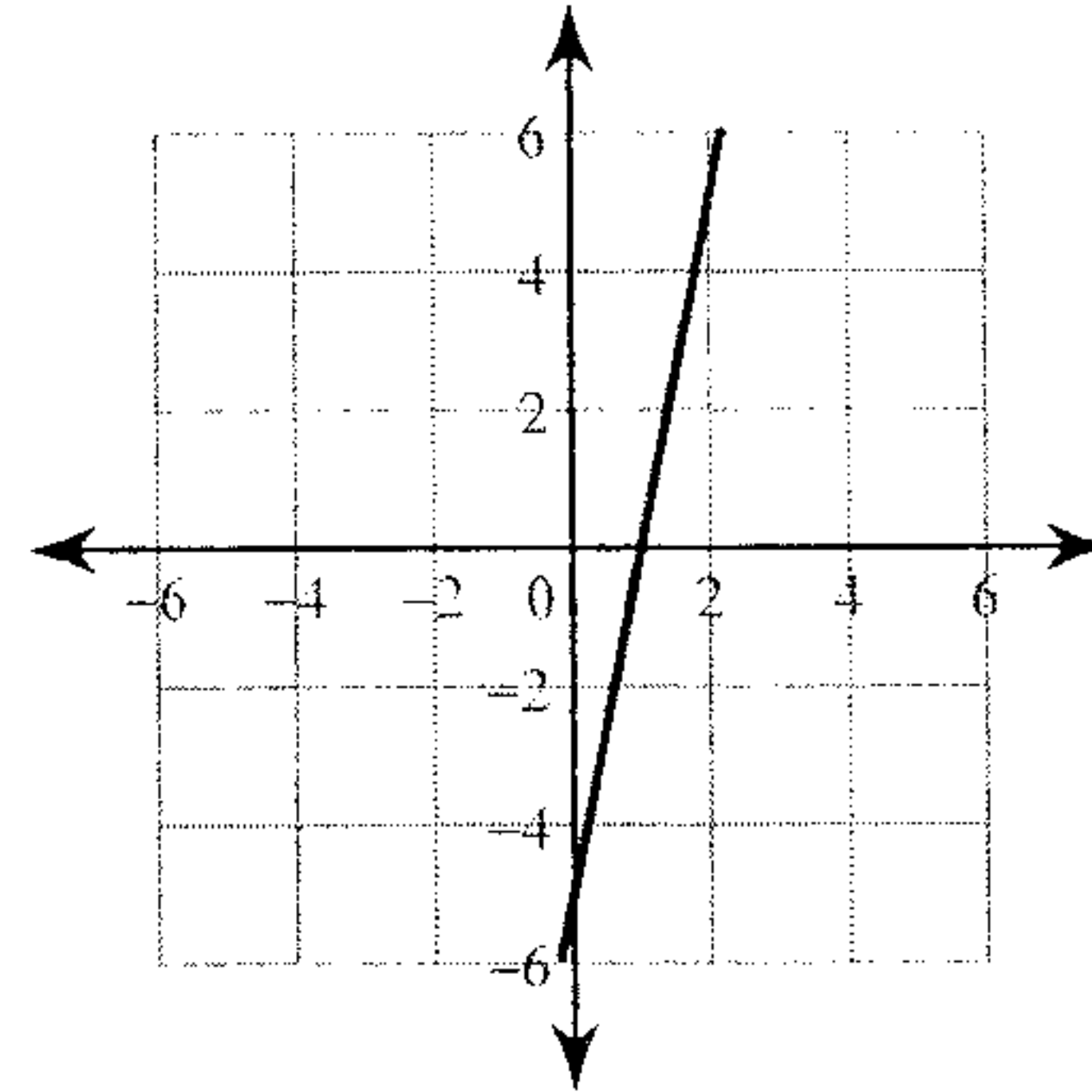

14) $6ab$

12)

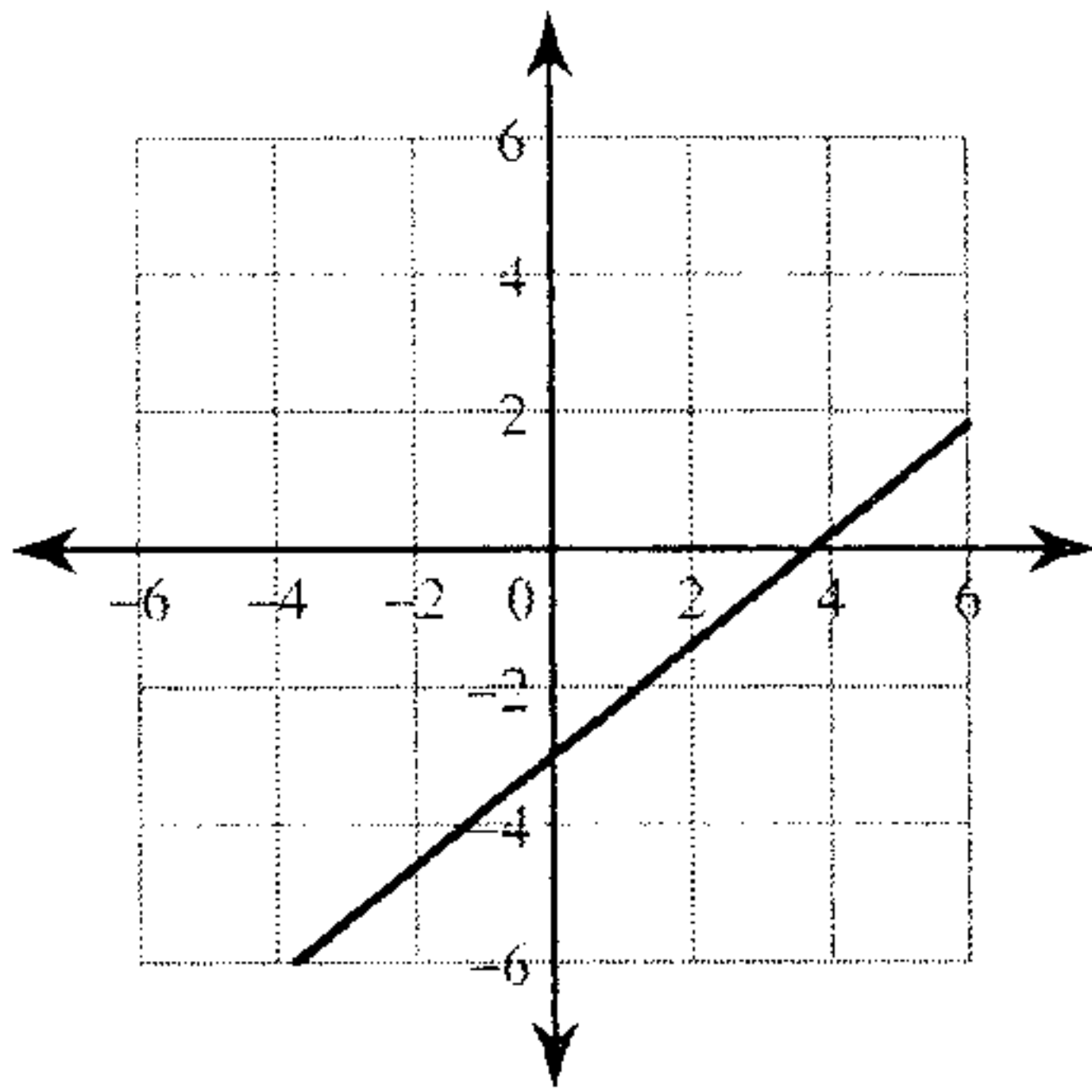

13) $8yx$

15) $2a$

16) $16xy$

17) $36m^3n$

18) $280x$

19) $240n^4$

20) $120y^3x^3$

21) $-11p^5 - 25p^4 + 19$

22) $6k^5 - 13k^3 - 6k^2$

23) $\sqrt{53}$

24) 9

25) $-9x + 7x^2$

26) $23n - 26$

27) 55.2

28) $\$23.12$

29) 16

30) $\$19.40$

31) $\{-22\}$

32) $\{-21\}$

33)

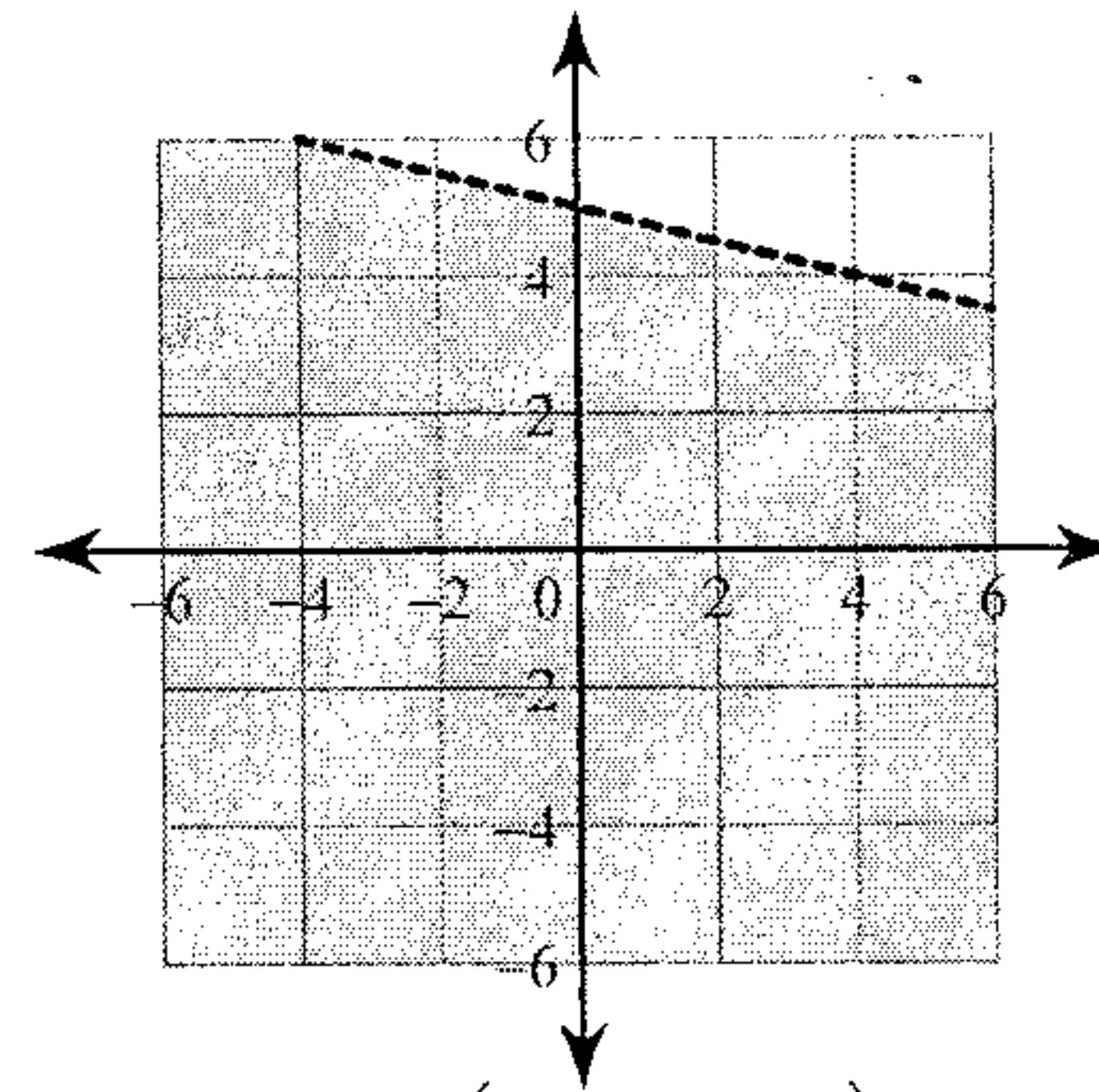

36) $(-11.5, 1)$

34)

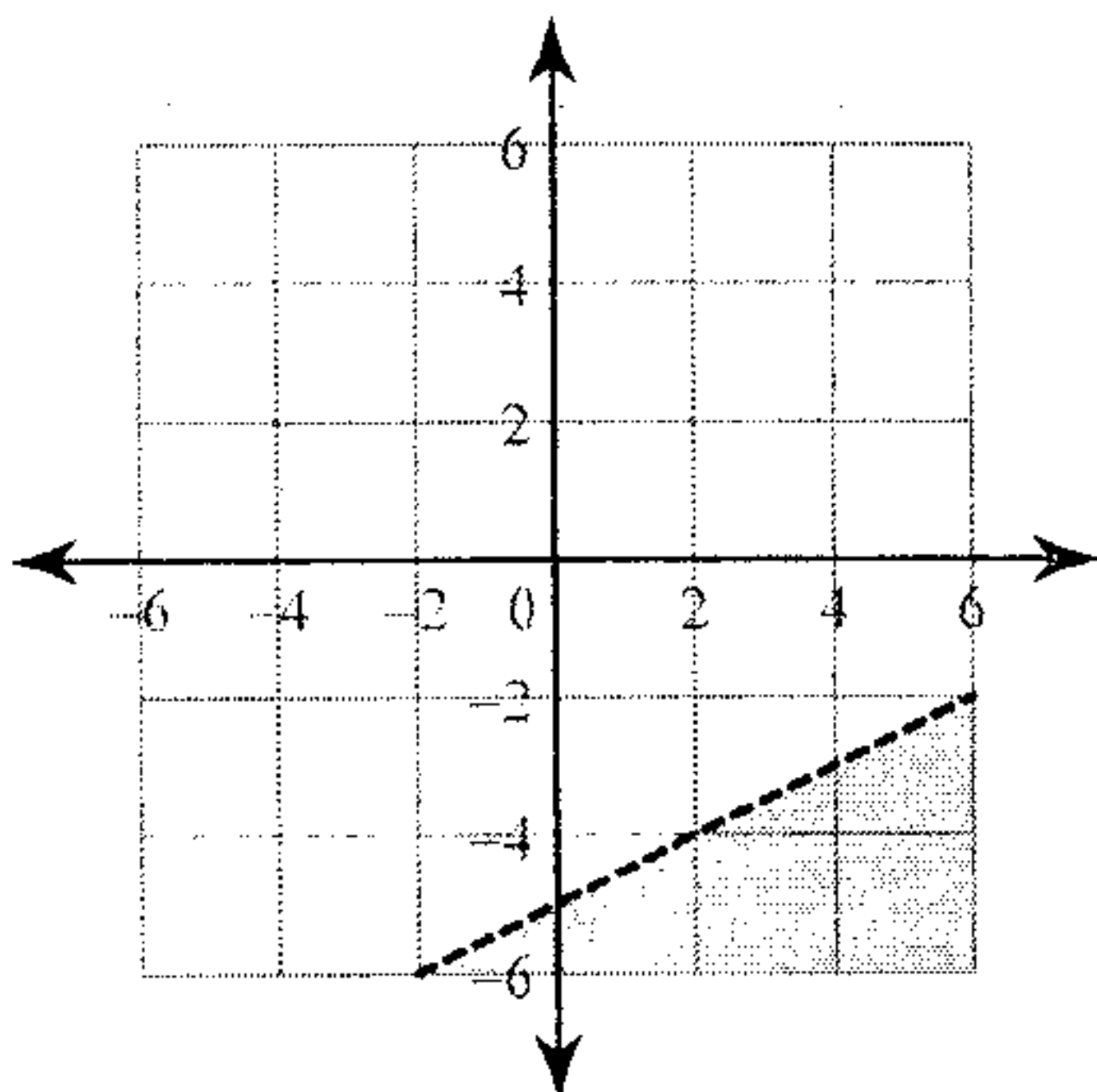

35) $(1.5, 4.5)$

37) $-15x^2 - 43x - 8$

38) $n^2 - 12n + 35$

39) 6.7

40) 6.6

41) 5.44×10^{-7}

42) 1.8×10^3

43) $-52b - 4$

44) $-57v + 77v^2$

45) 4

$$46) -\frac{3}{2}$$

$$47) y = -2x + 1$$

$$48) y = -\frac{1}{4}x - 1$$

$$49) x - y = -3$$

$$50) 4x + 3y = 12$$

Complex Numbers

Simplify.

1) $-2(i) - (7i)(-2 + 3i)$

2) $(7i)(-3 + 5i) + (8i)(3 + 3i)$

3) $(-5 + i) - (-2 + 7i)$

4) $-3(-4 + 4i) + (3i)(-7 - 8i)$

5) $(4i)(6i)(5 - 3i)$

6) $(-2 - 7i)(4 - 2i)$

7) $\frac{3}{-6i}$

8) $\frac{8}{4i}$

9) $\frac{\sqrt{54}}{\sqrt{30}}$

10) $\frac{3\sqrt{8}}{\sqrt{7}}$

Find the absolute value of each complex number.

11) $|18 - i|$

12) $|4 + 48i|$

Simplify.

13) $\frac{7}{1 - 2i}$

14) $\frac{1}{-10 - 9i}$

15) $\frac{9 - 2i}{5 + 6i}$

16) $\frac{-5 - 4i}{-9 + 3i}$

Answers to Complex Numbers (ID: 1)

1) $21 + 12i$

5) $-120 + 72i$

9) $\frac{3\sqrt{5}}{5}$

13) $\frac{7 + 14i}{5}$

2) $-59 + 3i$

6) $-22 - 24i$

10) $\frac{6\sqrt{14}}{7}$

14) $\frac{-10 + 9i}{181}$

3) $-3 - 6i$

7) $\frac{i}{2}$

11) $5\sqrt{13}$

15) $\frac{33 - 64i}{61}$

4) $36 - 33i$

8) $-2i$

12) $4\sqrt{145}$

16) $\frac{11 + 17i}{30}$

Quadratics, Radicals, Absolute Value

Solve each equation by completing the square.

1) $n^2 + 16n + 9 = -6$

2) $x^2 - 18x + 34 = -10$

Solve each equation by factoring.

3) $m^2 - 9m = -8$

4) $p^2 - 13p = -40$

Solve each equation by taking square roots.

5) $17x^2 - 18 = 4249$

6) $2n^2 + 10 = 12$

Solve each equation with the quadratic formula.

7) $4b^2 - 4b = 2b^2 + 3$

8) $5r^2 - 5r + 12 = 8 + r$

Sketch the graph of each function. Label the Vertex, Axis of symmetry, y-intercept and x-intercepts. State the domain and range.

9) $y = 2x^2 - 14x + 27$

10) $y = -2x^2 - 18x - 43$

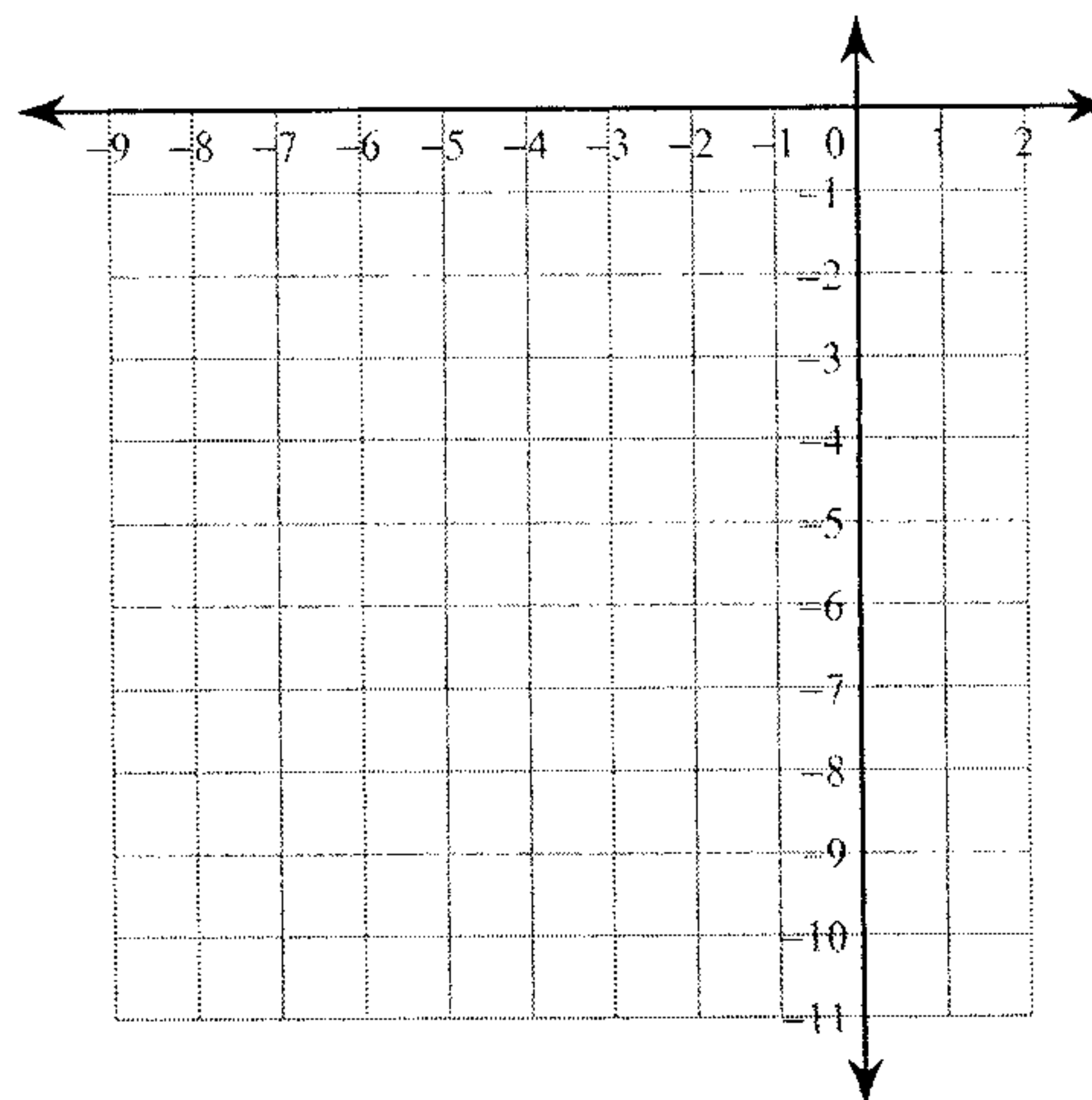
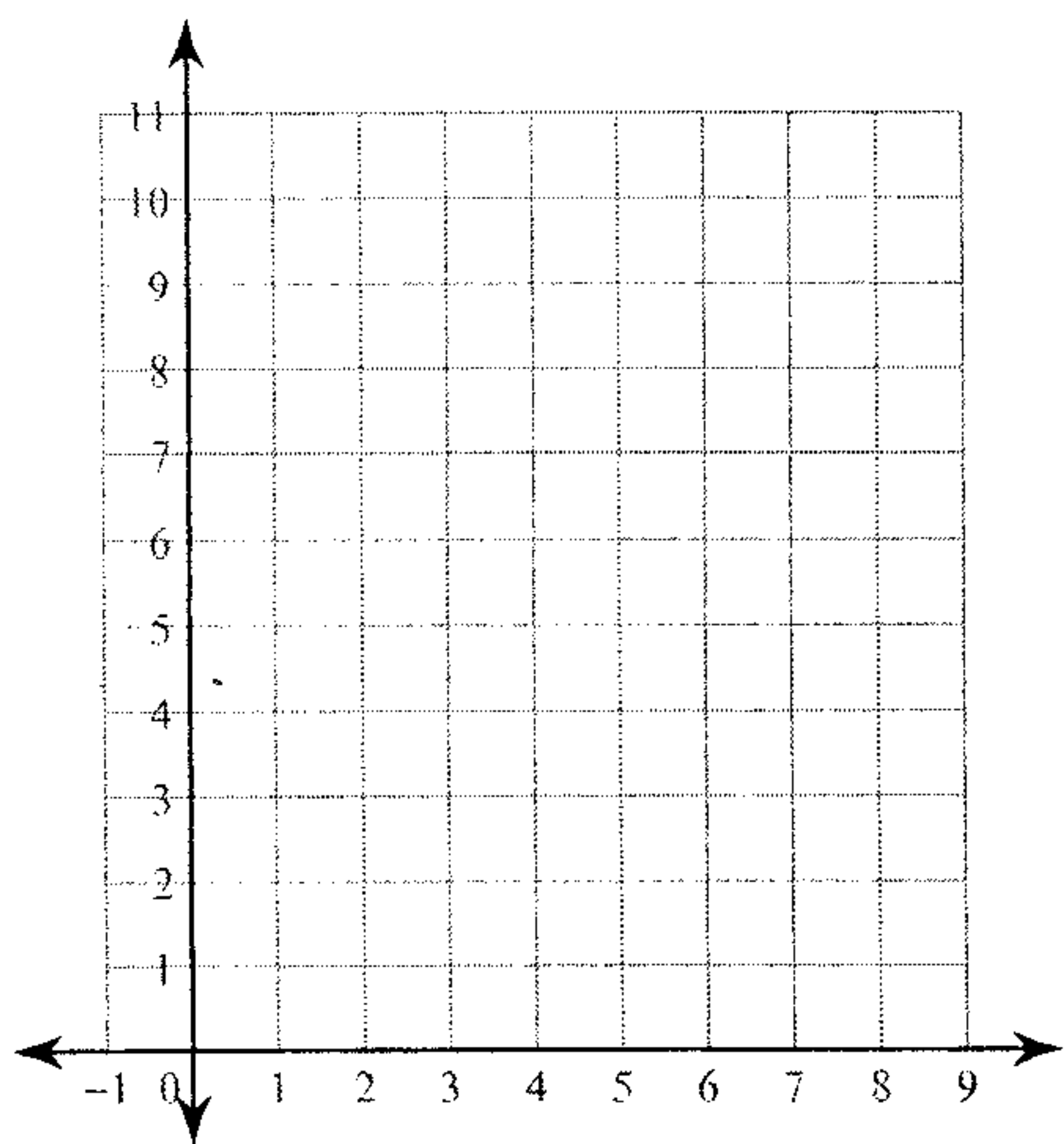

11) $y \geq x^2 - x - 1$

12) $y \geq -2x^2 + 2x + 3$

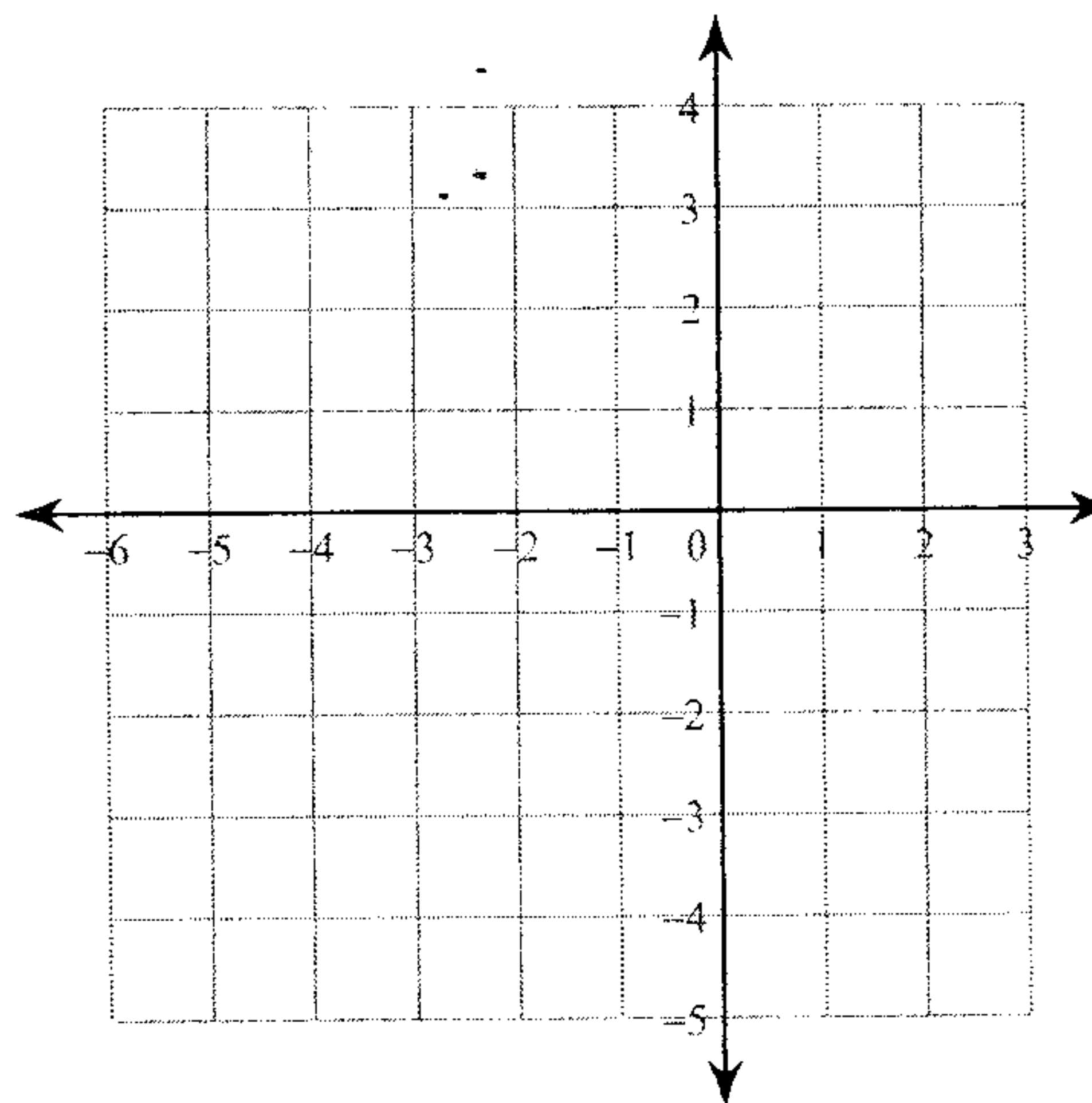
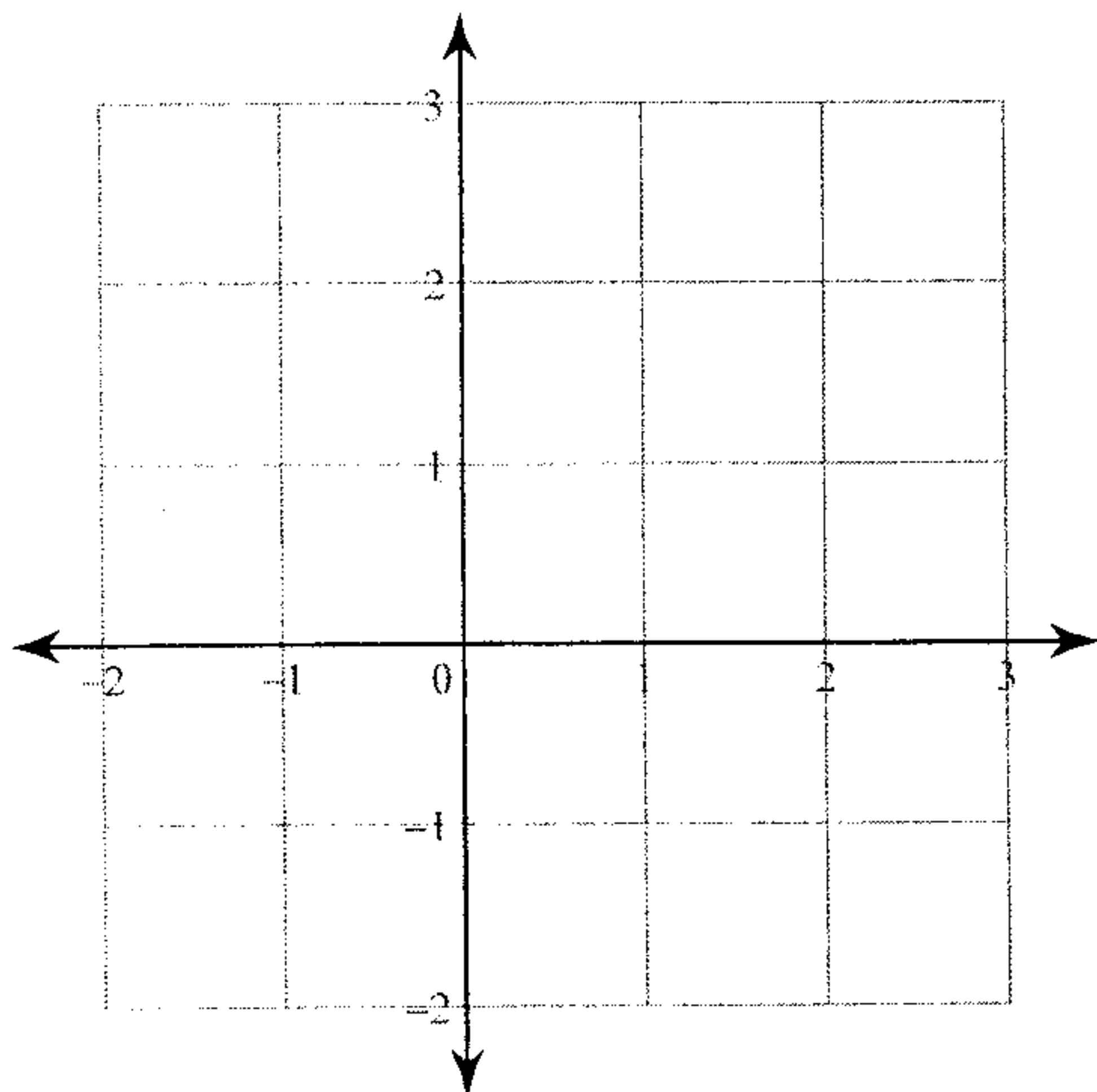

Simplify.

13) $-\sqrt{72} + 3\sqrt{32} - 3\sqrt{3} - 2\sqrt{128}$

14) $-2\sqrt{7} + 3\sqrt{7} - \sqrt{8} - \sqrt{6}$

15) $\frac{2\sqrt{2}}{4 - \sqrt{5}}$

16) $\frac{3}{2\sqrt{3} - 5\sqrt{2}}$

Solve each equation. Remember to check for extraneous solutions.

17) $4 = 3 + \sqrt{3 - r}$

18) $\sqrt{33x - 2} = 8$

Simplify.

19) $\sqrt{10}(2 - 5\sqrt{2})$

20) $-2\sqrt{2}(\sqrt{5} + \sqrt{2})$

Solve each equation.

21) $\frac{|2n - 7|}{7} = 5$

22) $-1 + |10 - 8a| = 33$

Solve each inequality and graph its solution.

23) $-3|4x + 5| > -51$

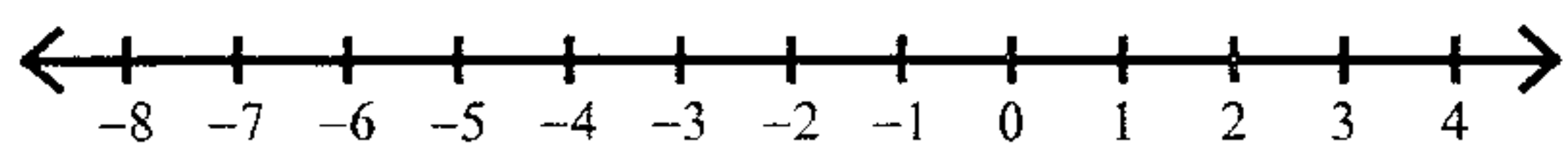

24) $\frac{|6 + 4m|}{3} \leq 5$

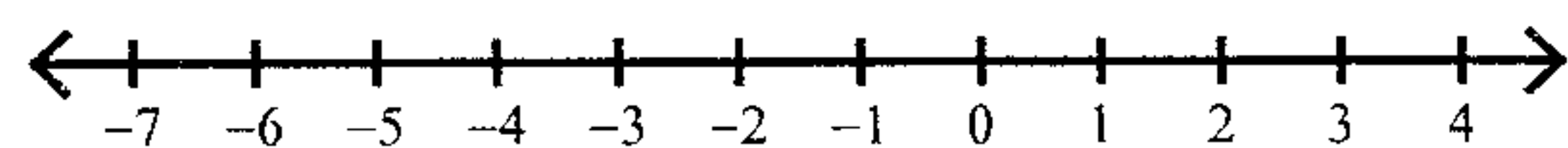

Graph each equation.

25) $y = |x + 3| + 3$

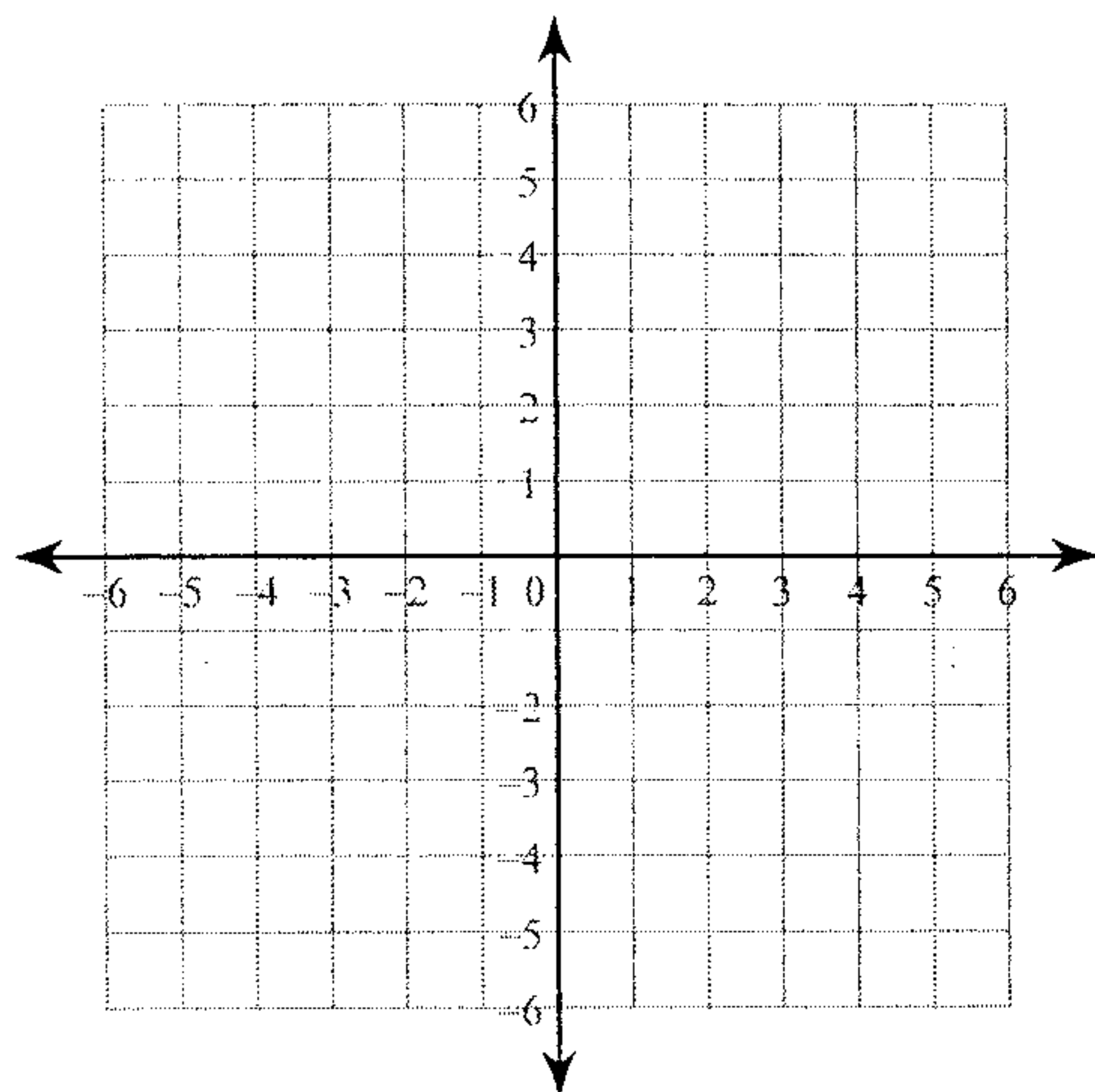

26) $y = -|x + 4| - 4$

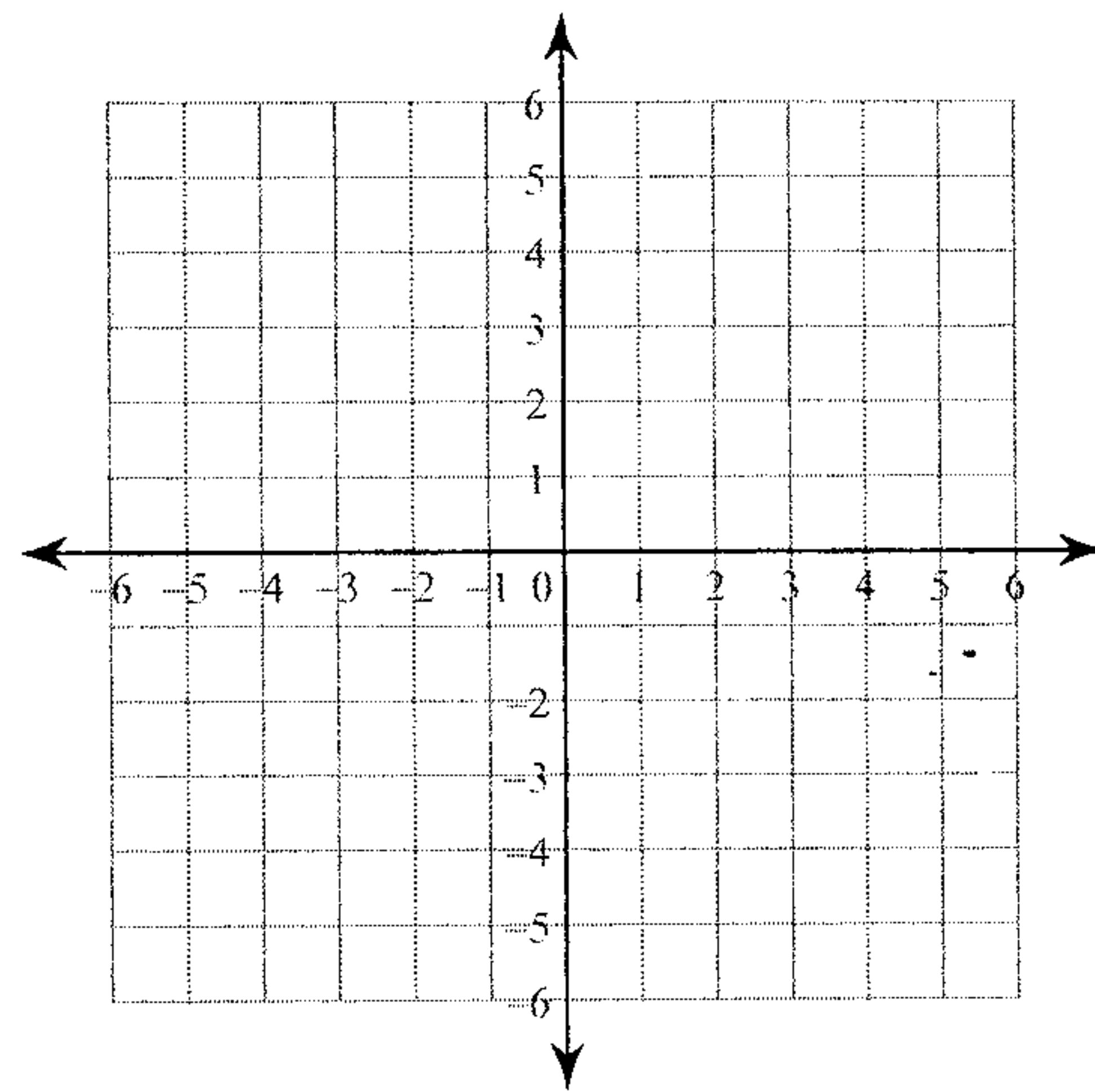

Answers to Quadratics, Radicals, Absolute Value (ID: 1)

1) $\{-1, -15\}$

2) $\{15.083, 2.917\}$

3) $\{1, 8\}$

4) $\{5, 8\}$

5) $\{15.843, -15.843\}$

6) $\{1, -1\}$

7) $\left\{\frac{2 + \sqrt{10}}{2}, \frac{2 - \sqrt{10}}{2}\right\}$

8) No solution.

9)

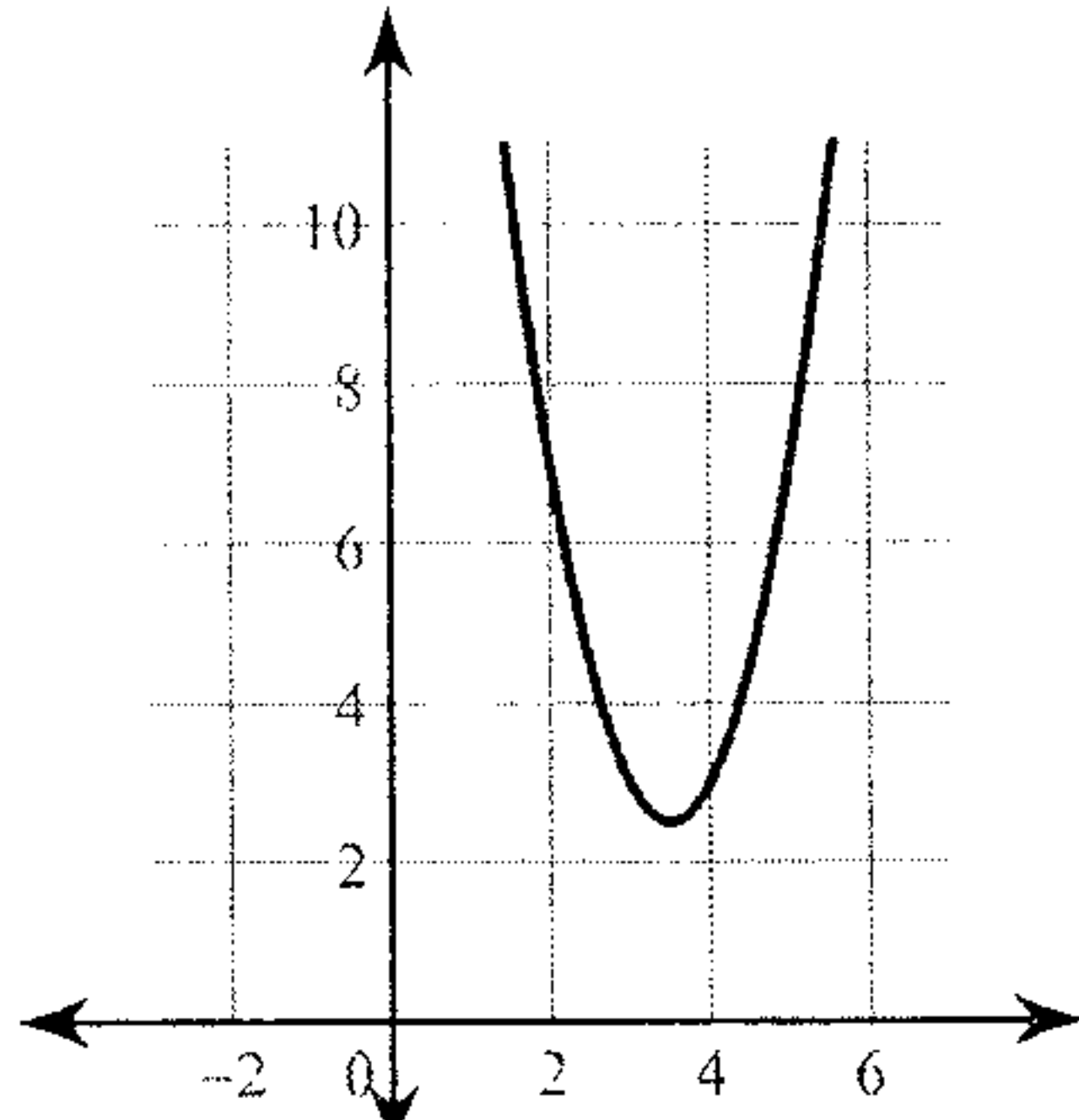

10)

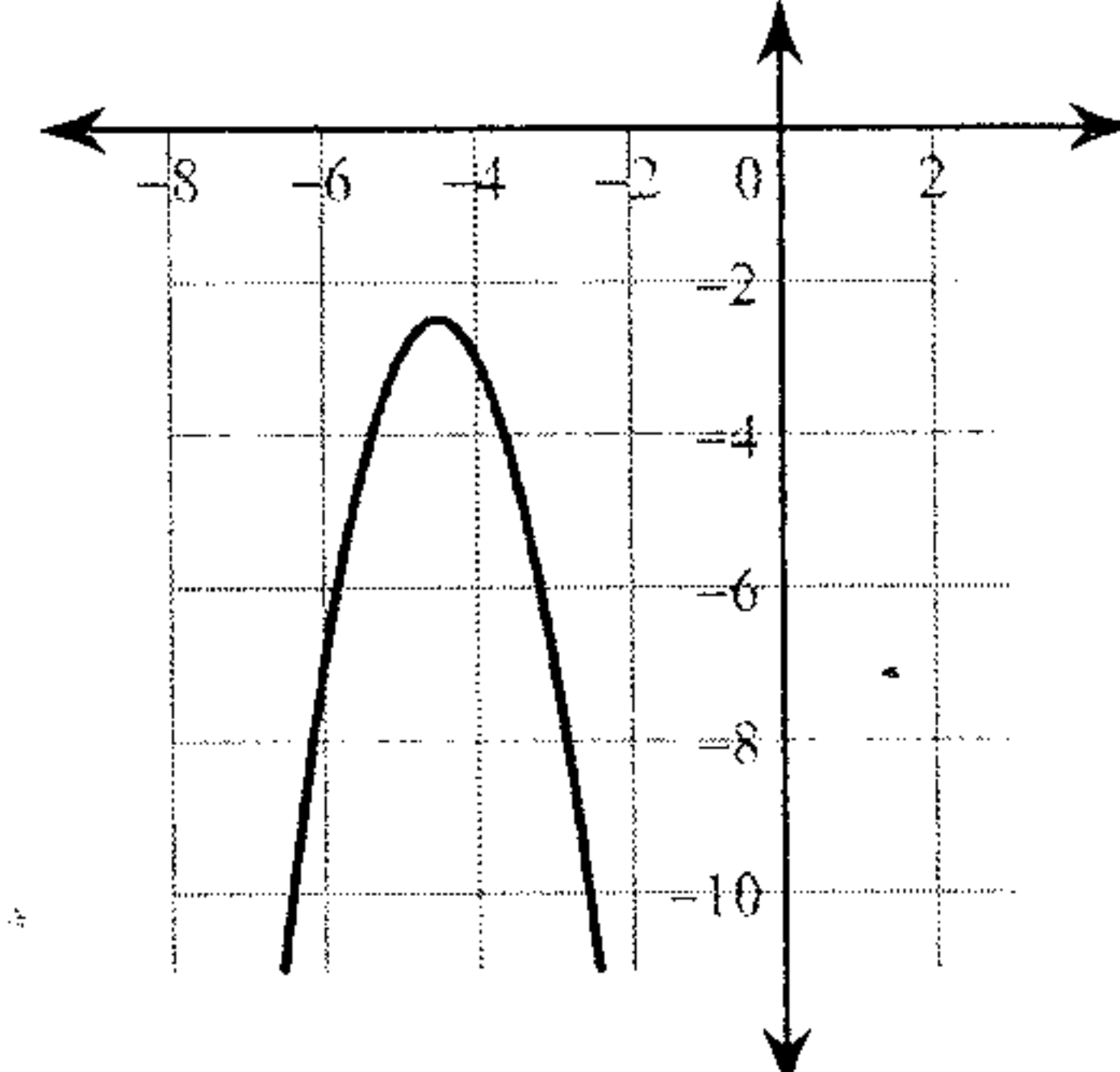

11)

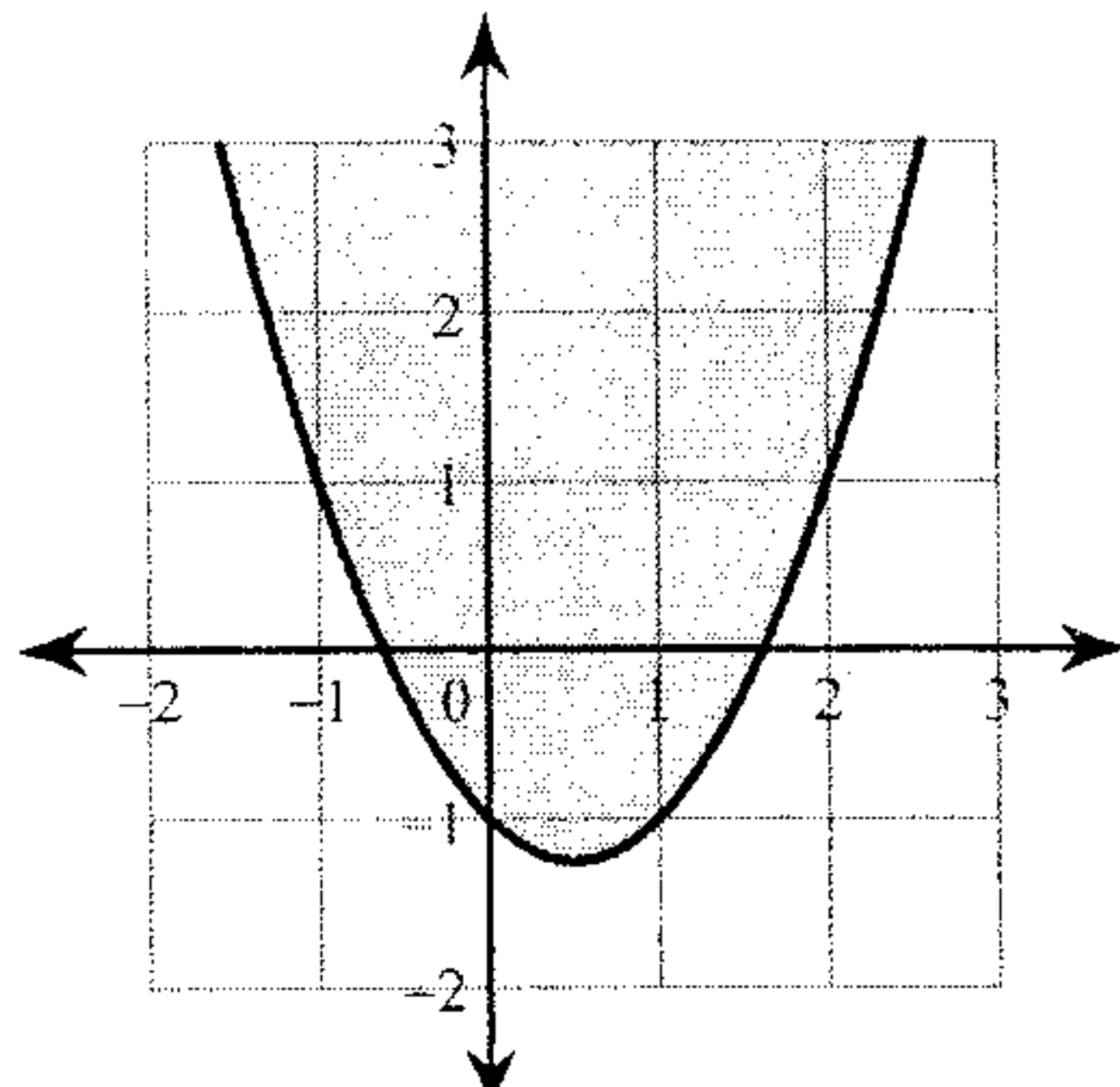

12)

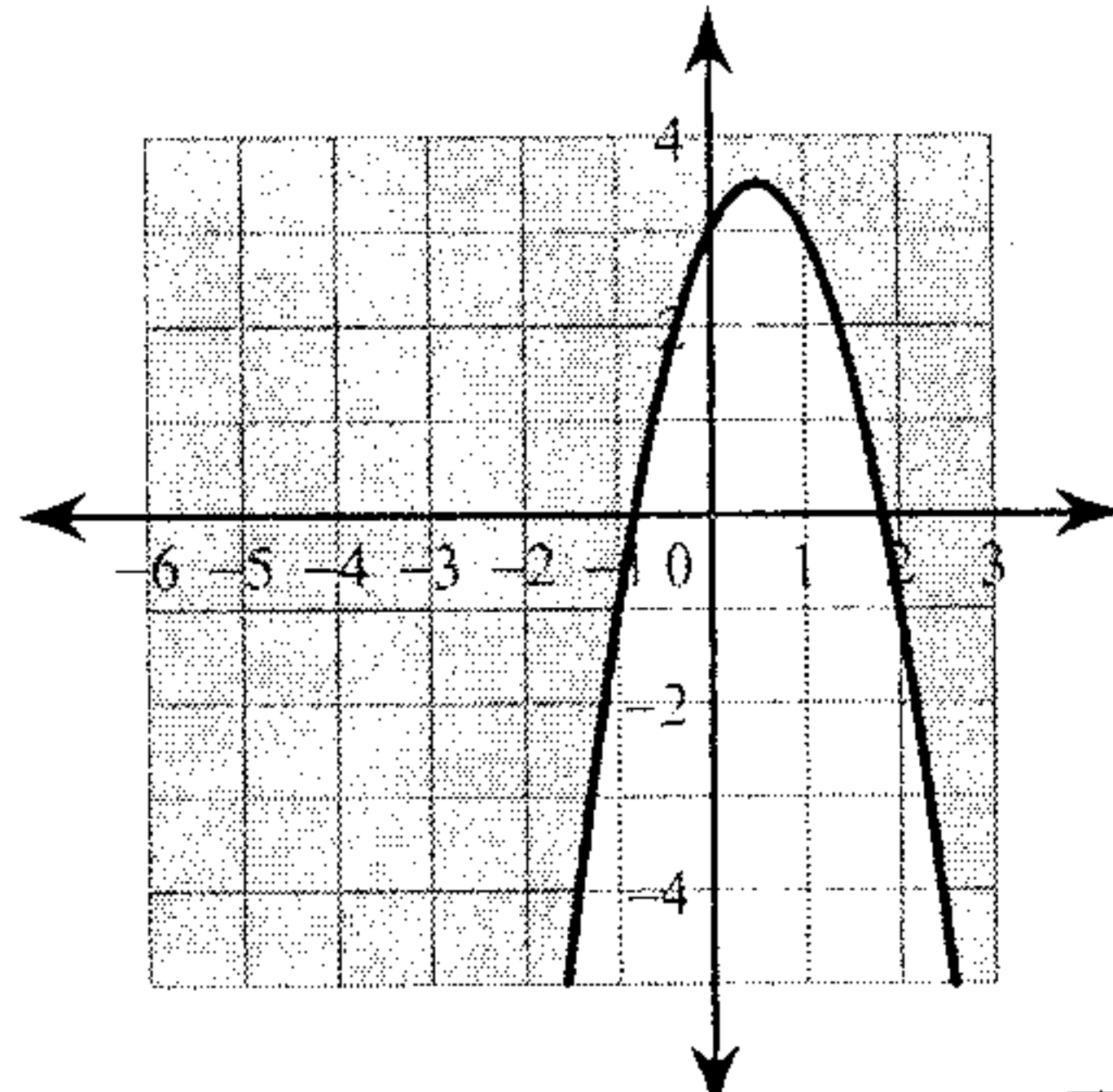

13) $-10\sqrt{2} - 3\sqrt{3}$

14) $\sqrt{7} - 2\sqrt{2} - \sqrt{6}$

15) $\frac{8\sqrt{2} + 2\sqrt{10}}{11}$

16) $\frac{-6\sqrt{3} - 15\sqrt{2}}{38}$

17) $\{2\}$

18) $\{2\}$

19) $2\sqrt{10} - 10\sqrt{5}$

20) $-2\sqrt{10} - 4$

21) $\{21, -14\}$

22) $\left\{-3, \frac{11}{2}\right\}$

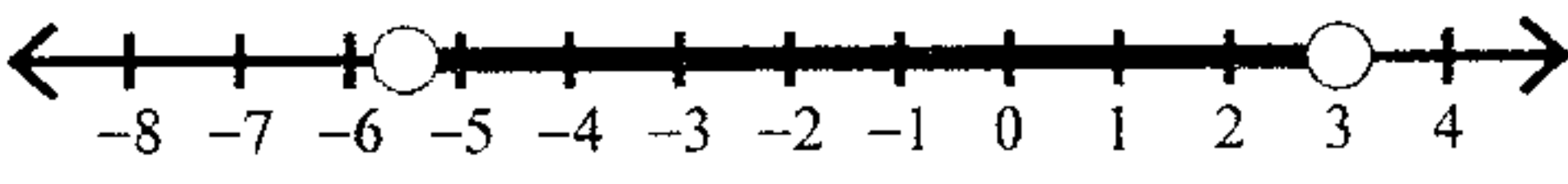
23) $-\frac{11}{2} < x < 3$: 

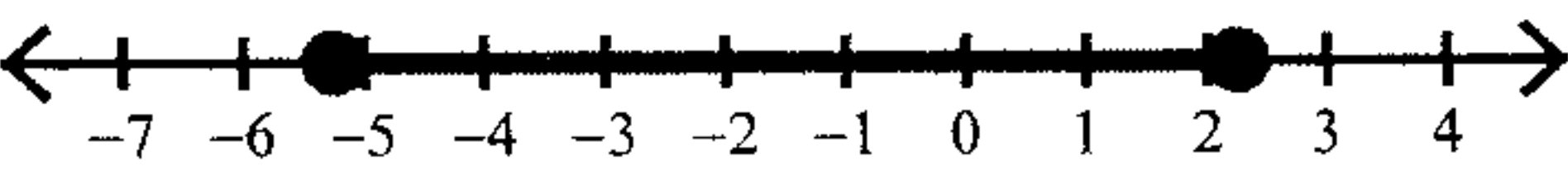
24) $-\frac{21}{4} \leq m \leq \frac{9}{4}$: 

25)

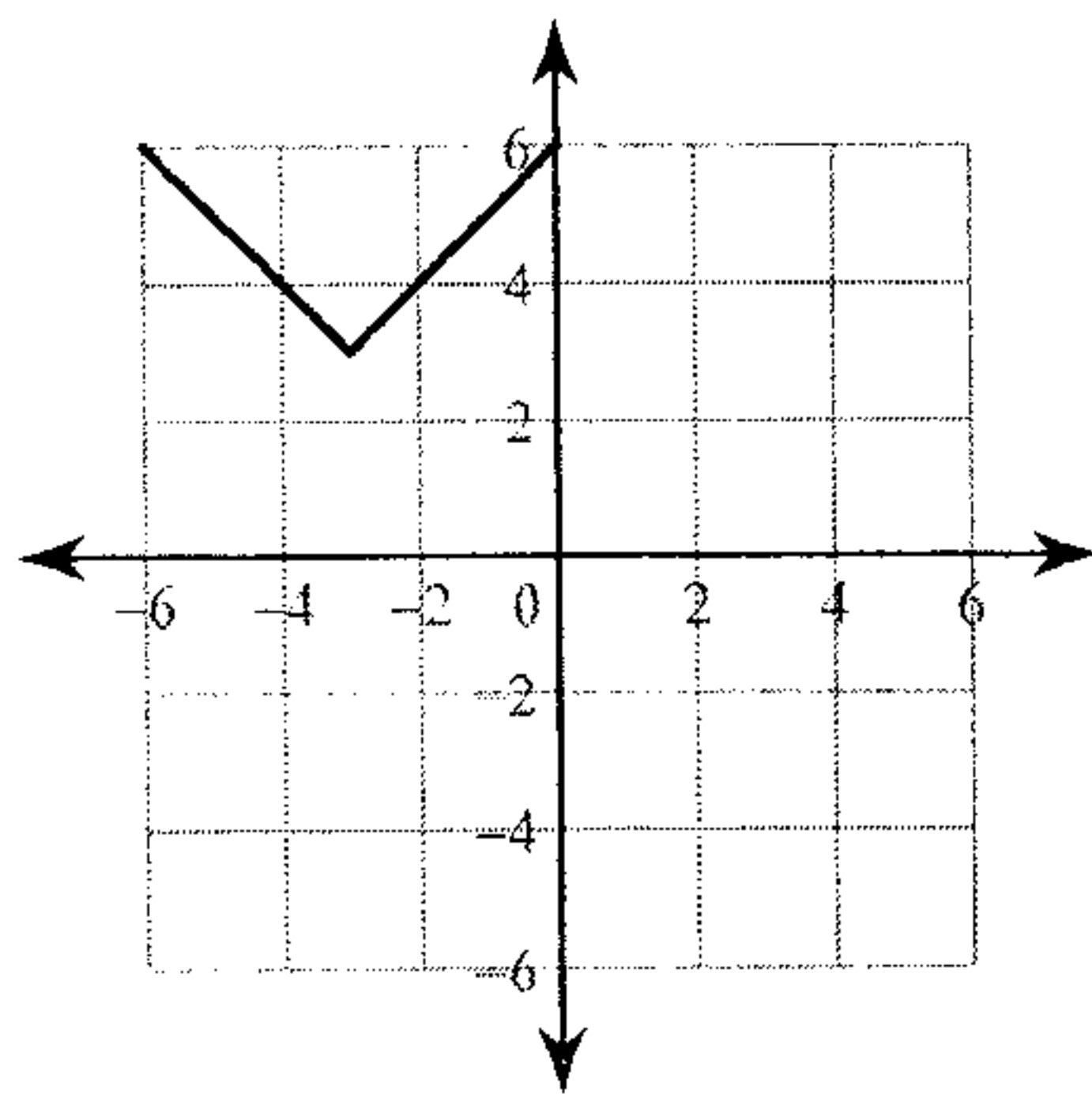

26)

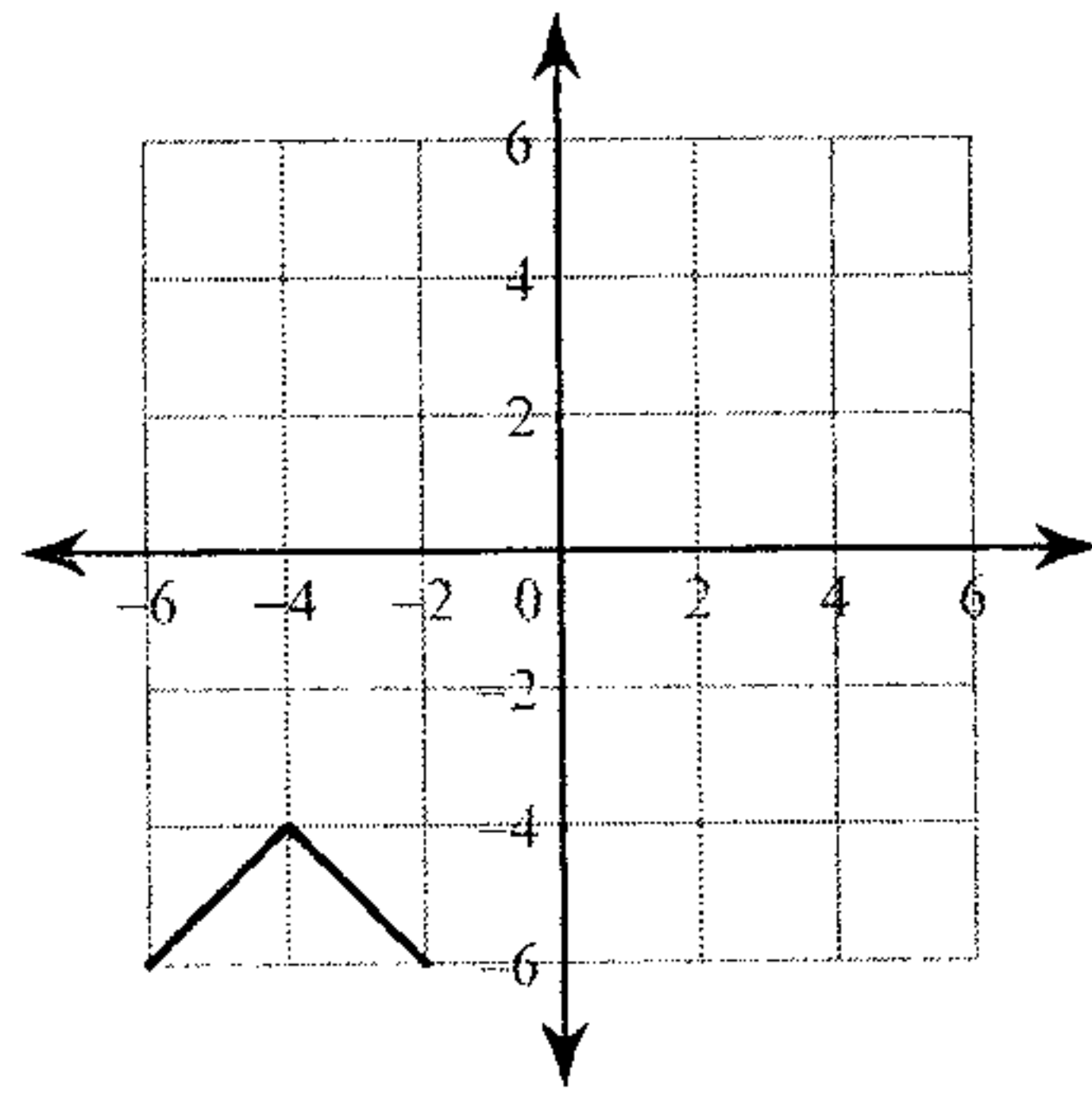

Circles

Find the measure of the arc or central angle indicated. Assume that lines which appear to be diameters are actual diameters.

1) $m\widehat{VWU}$

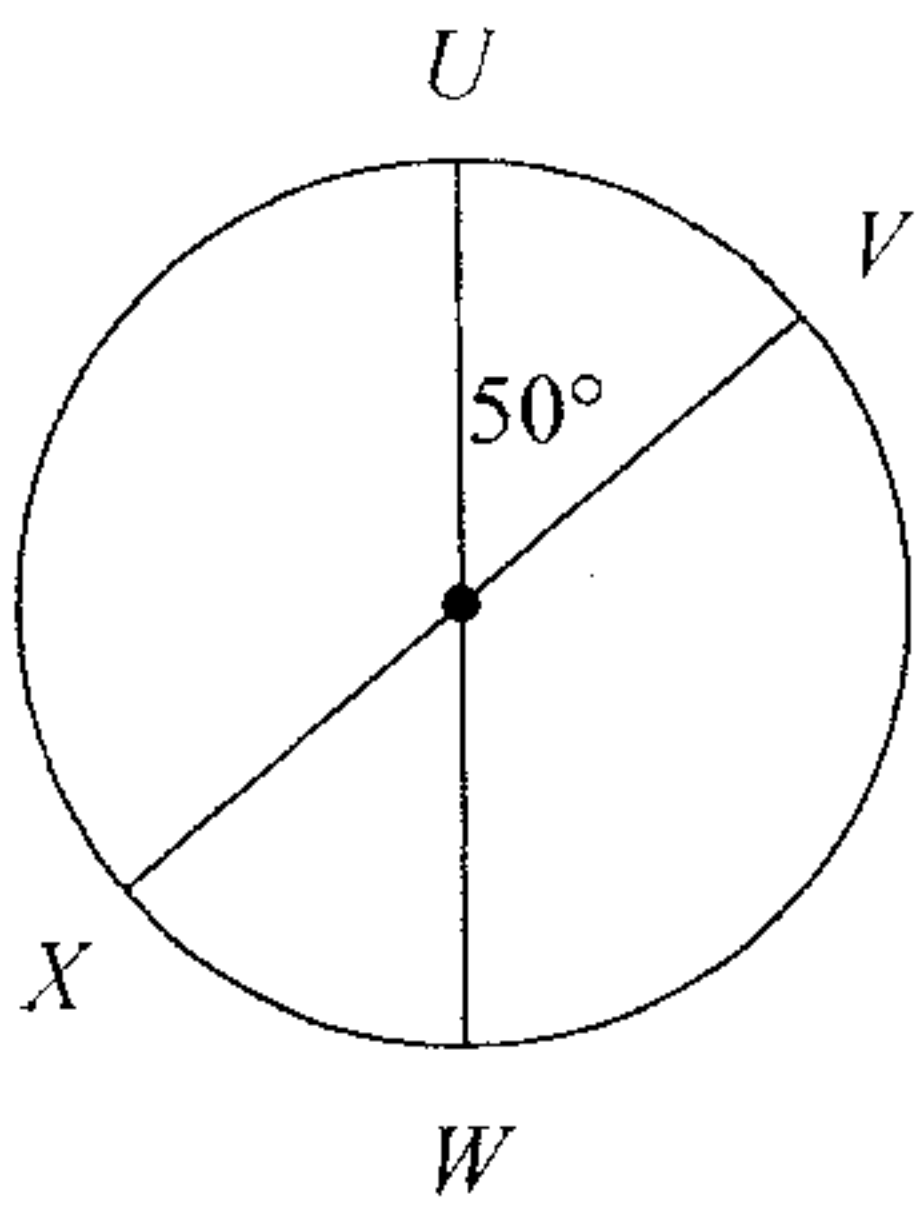

2) $m\angle DCE$

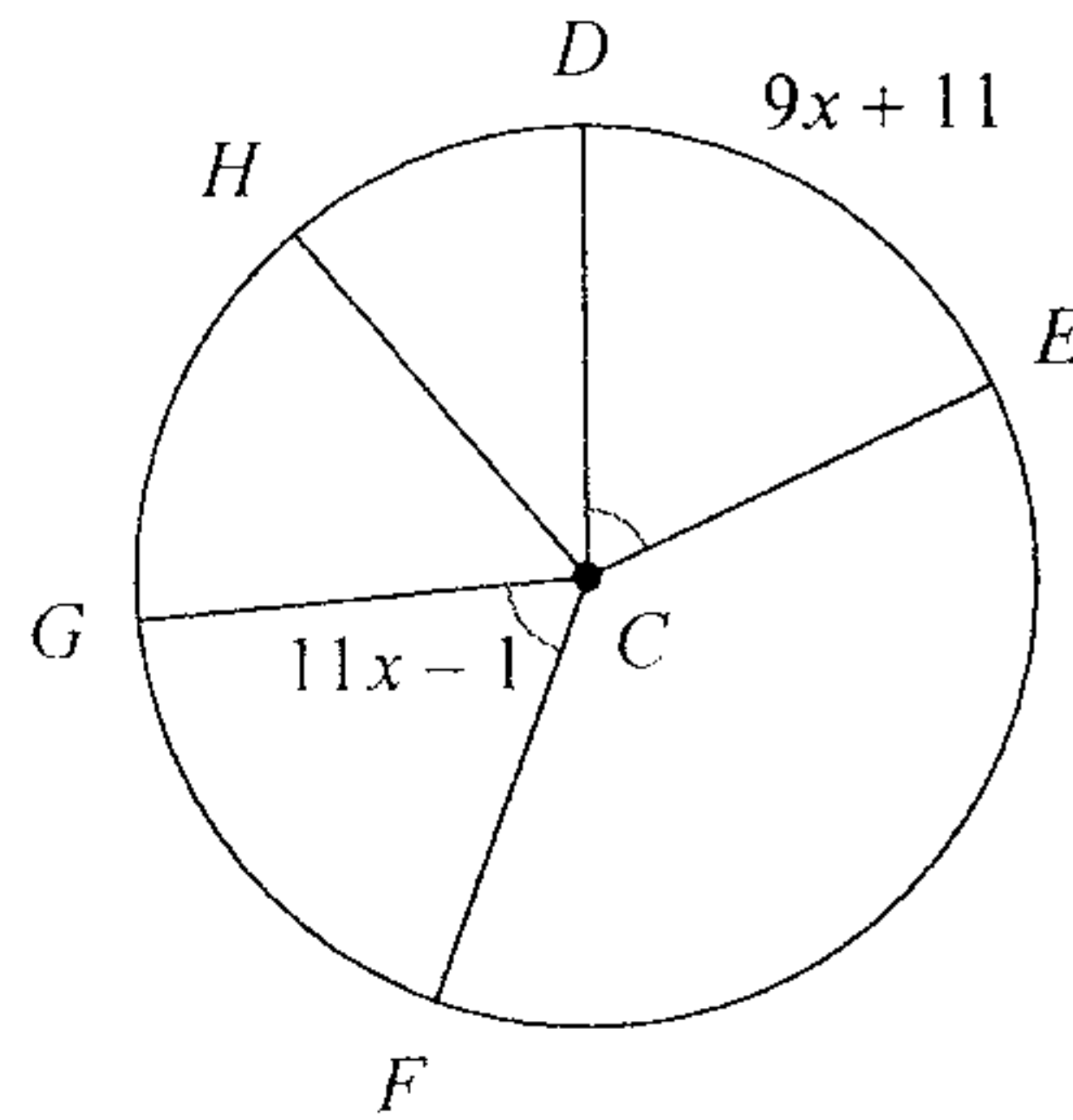

Find the measure of the arc or angle indicated.

3)

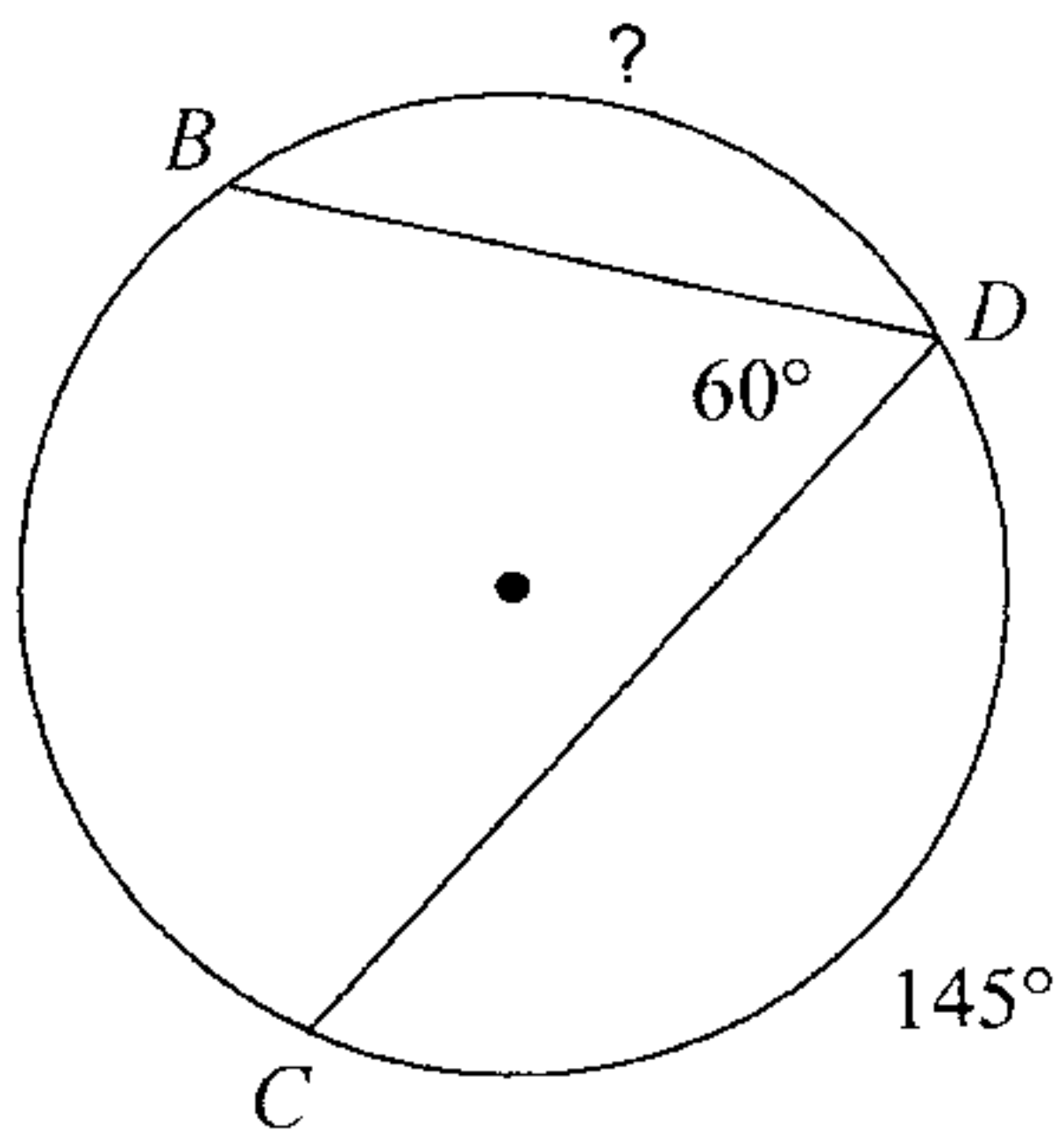

4)

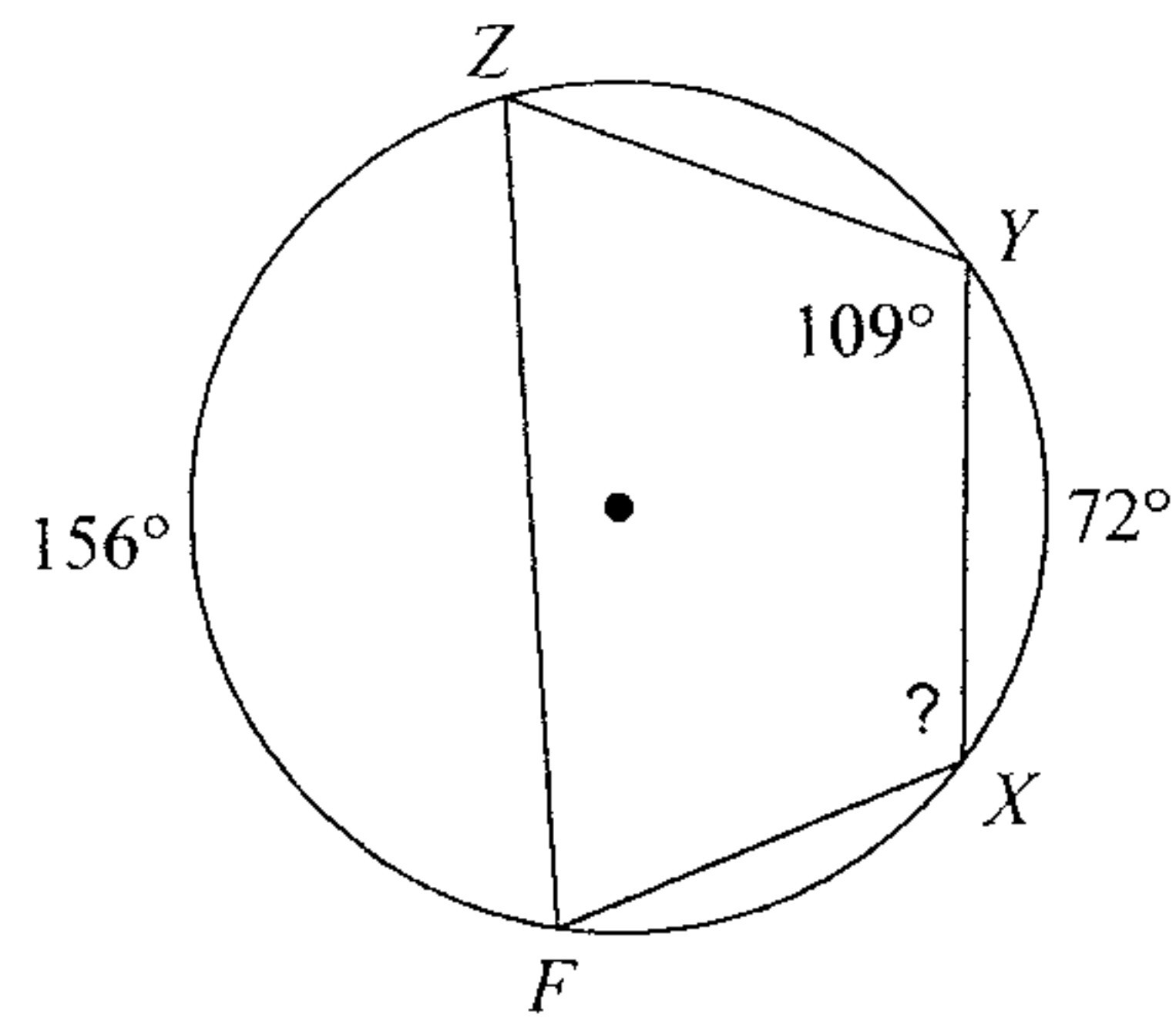

Solve for x and y .

5)

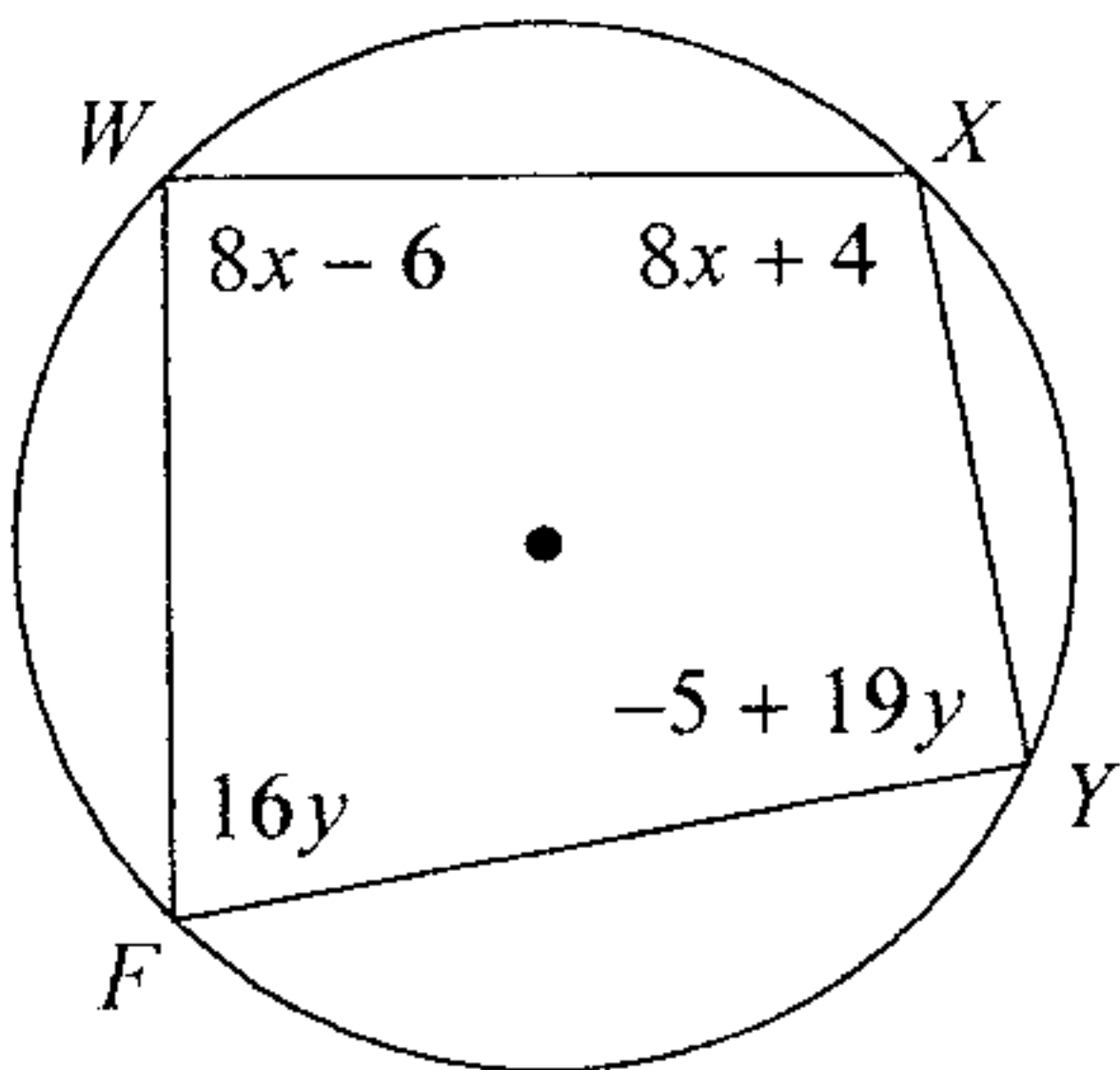

6)

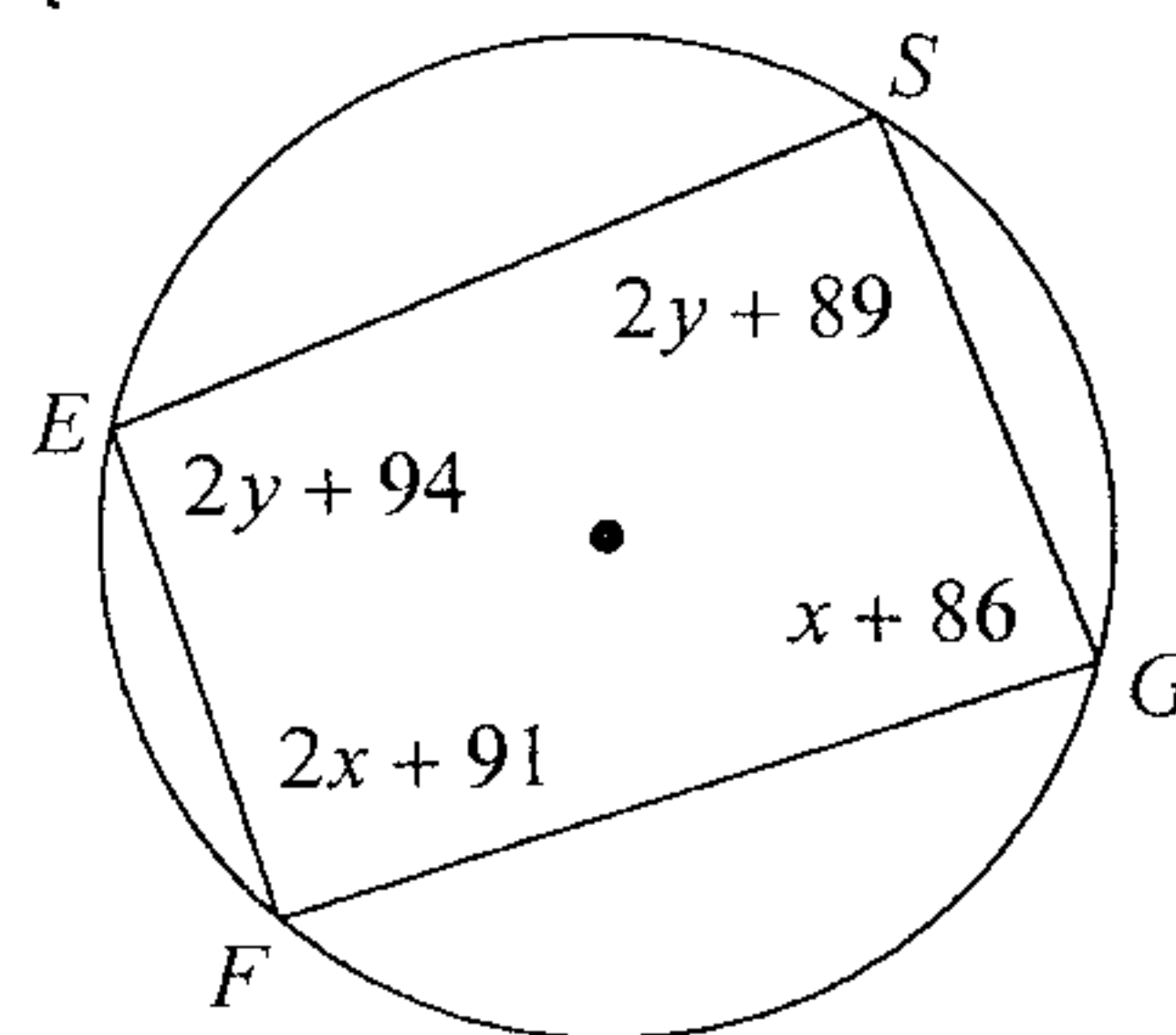

Find the measure of the arc or angle indicated. Assume that lines which appear tangent are tangent.

7)

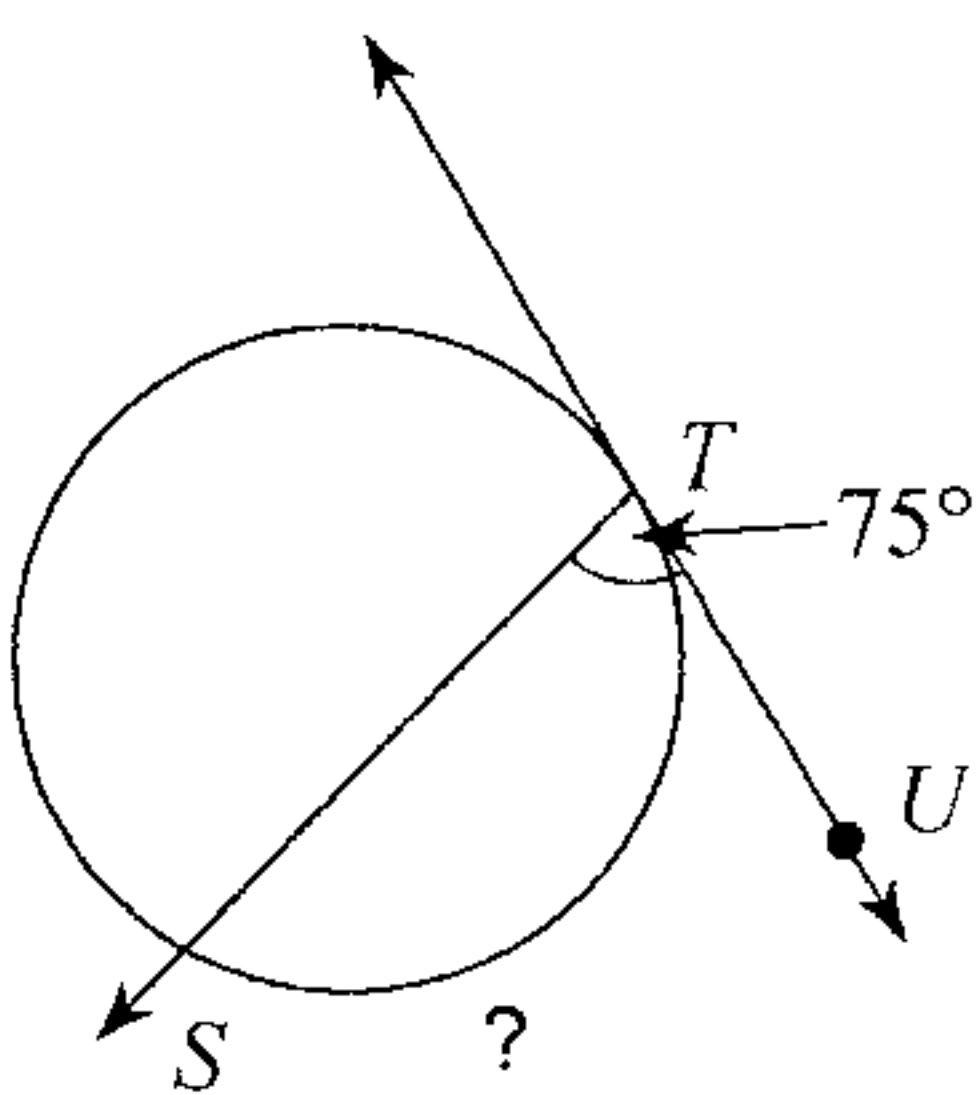

8)

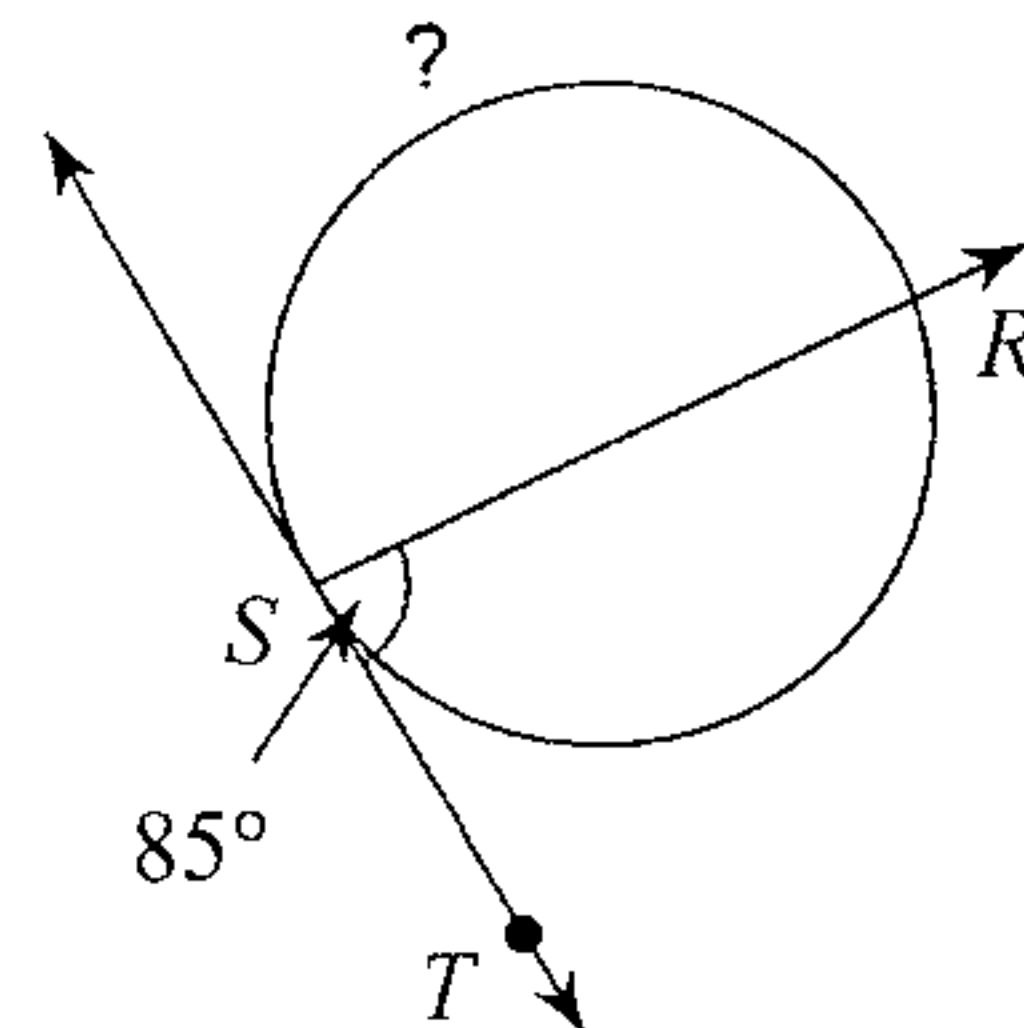

9)

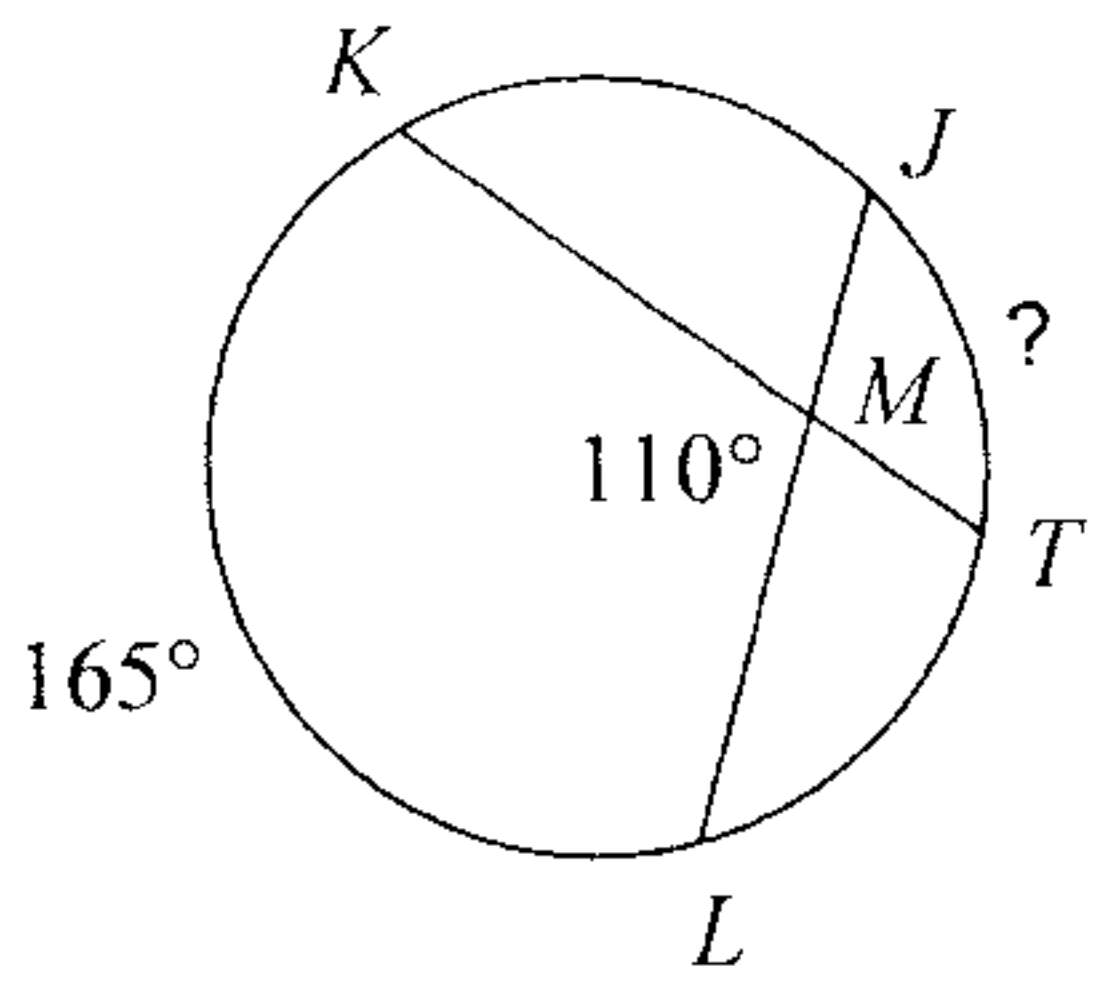

10)

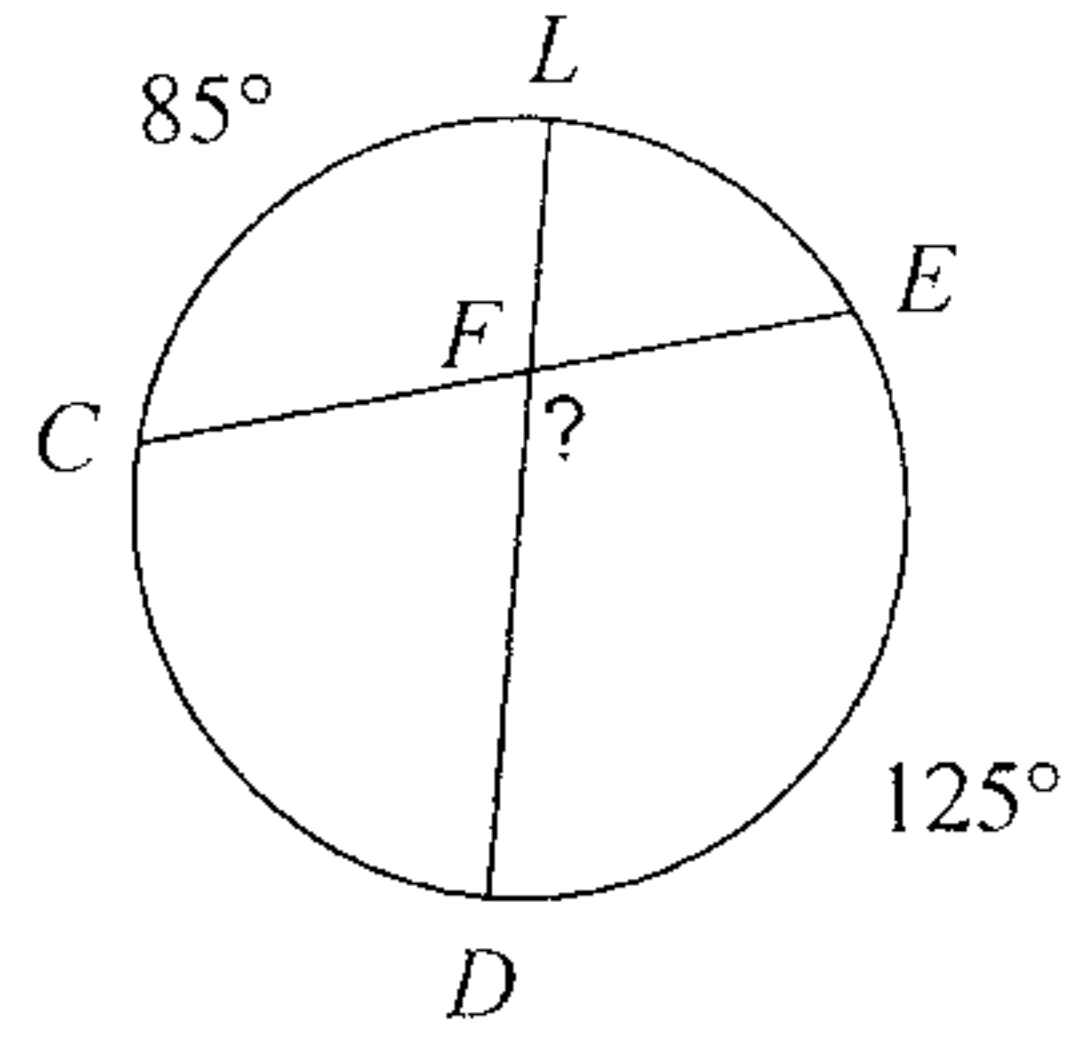

11)

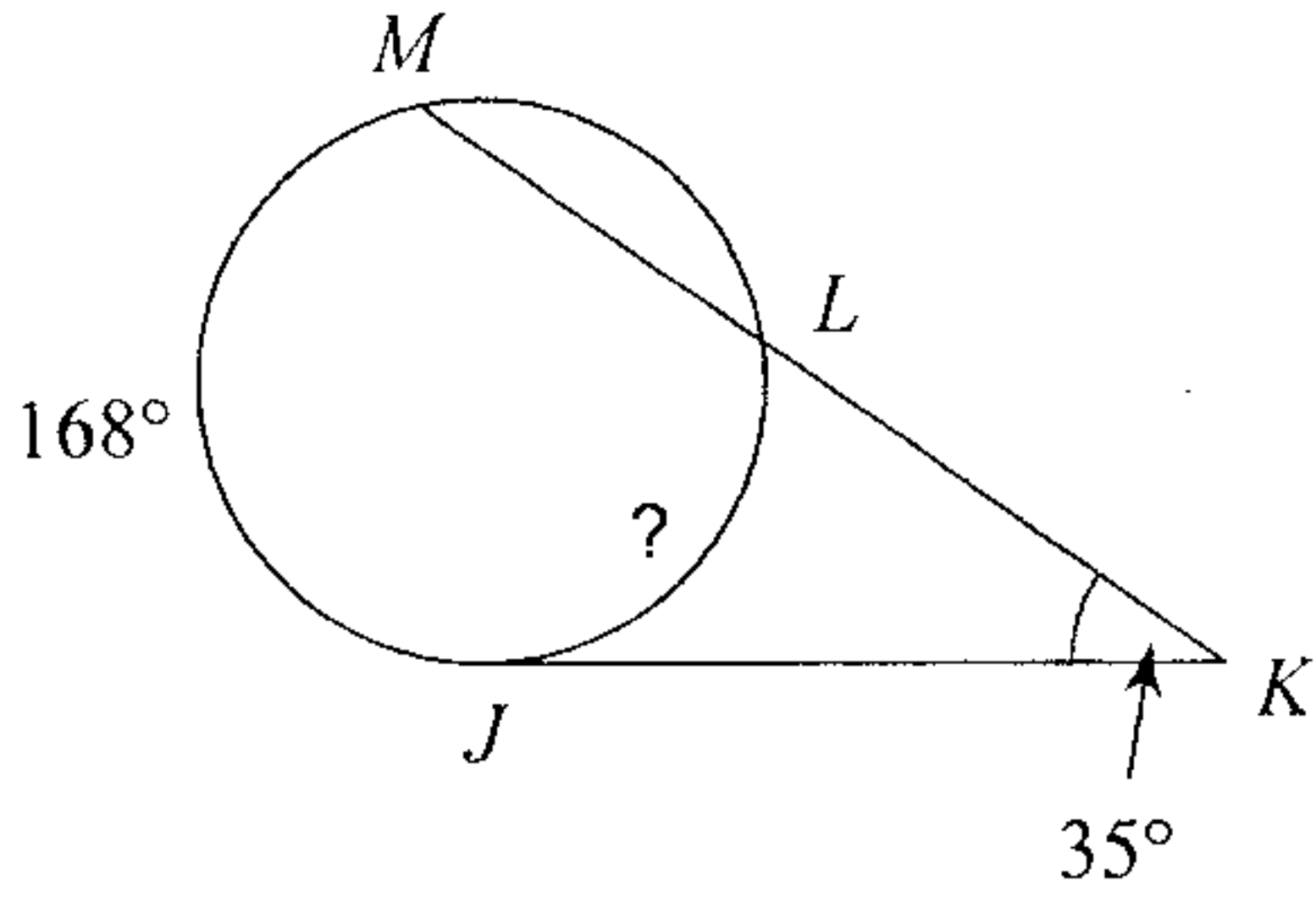

12)

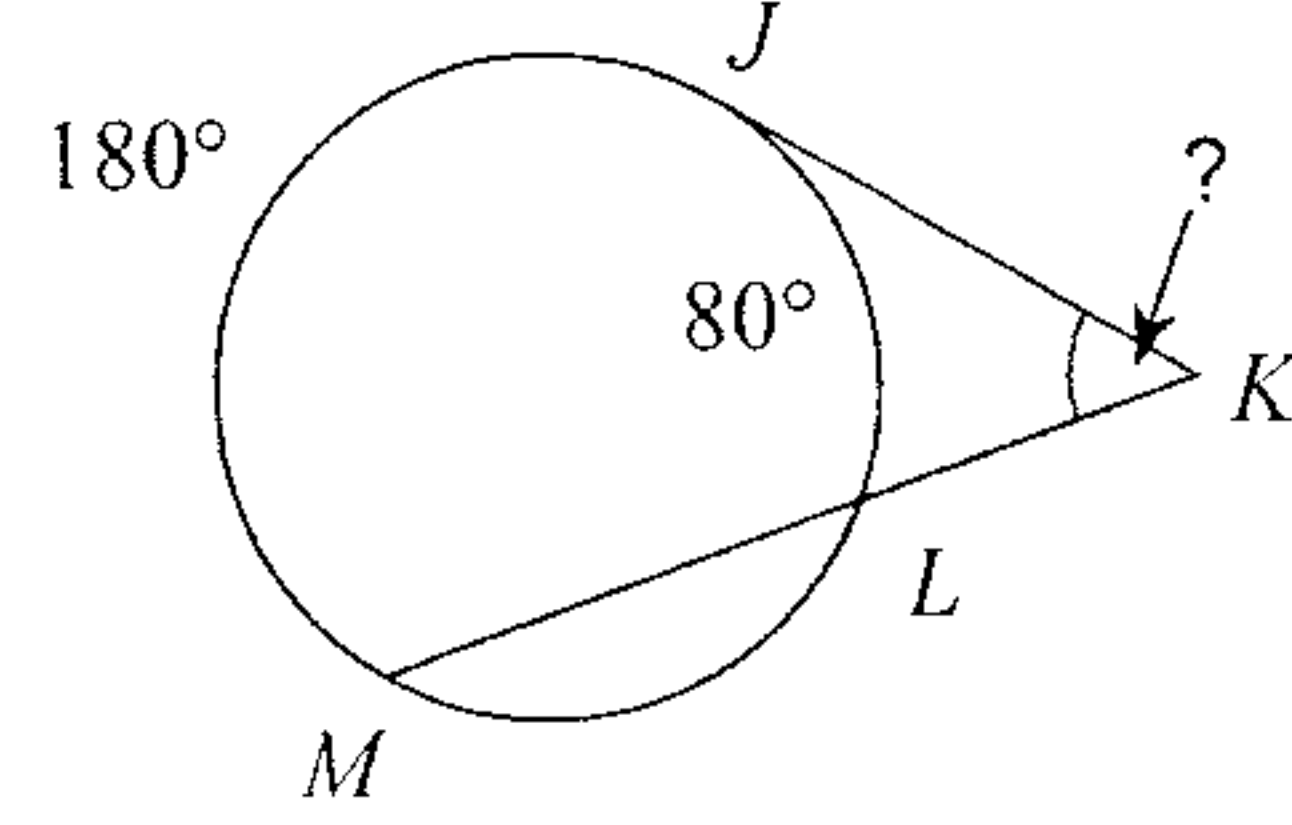

13)

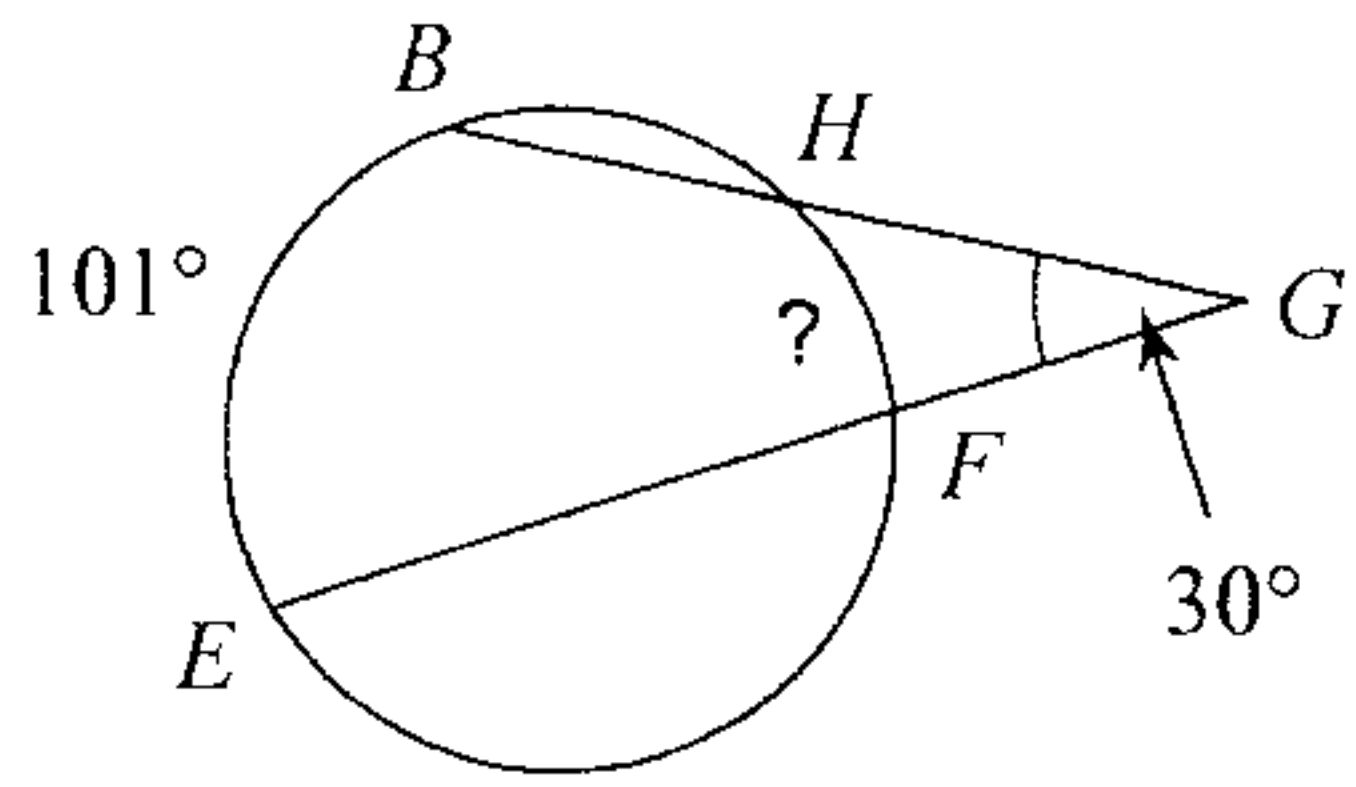

14)

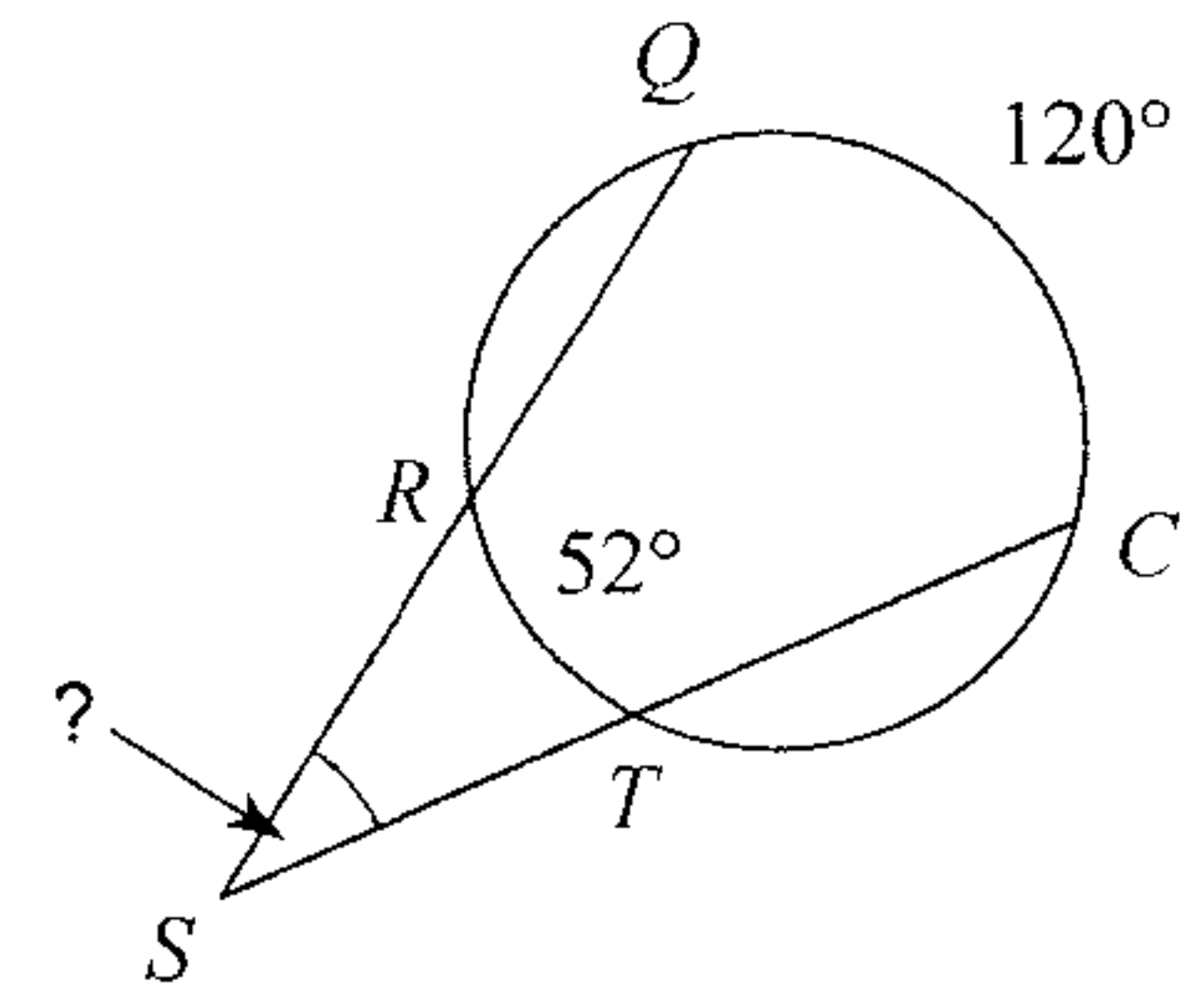

15)

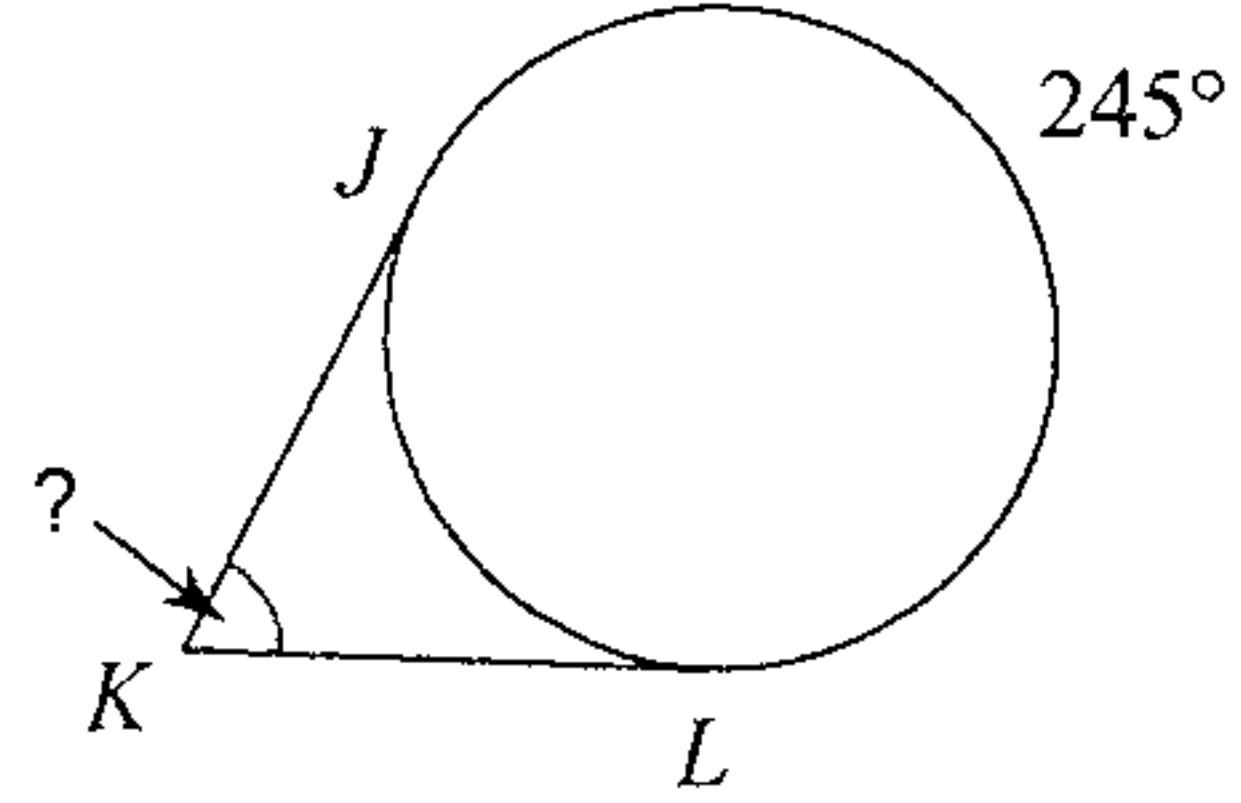

16)

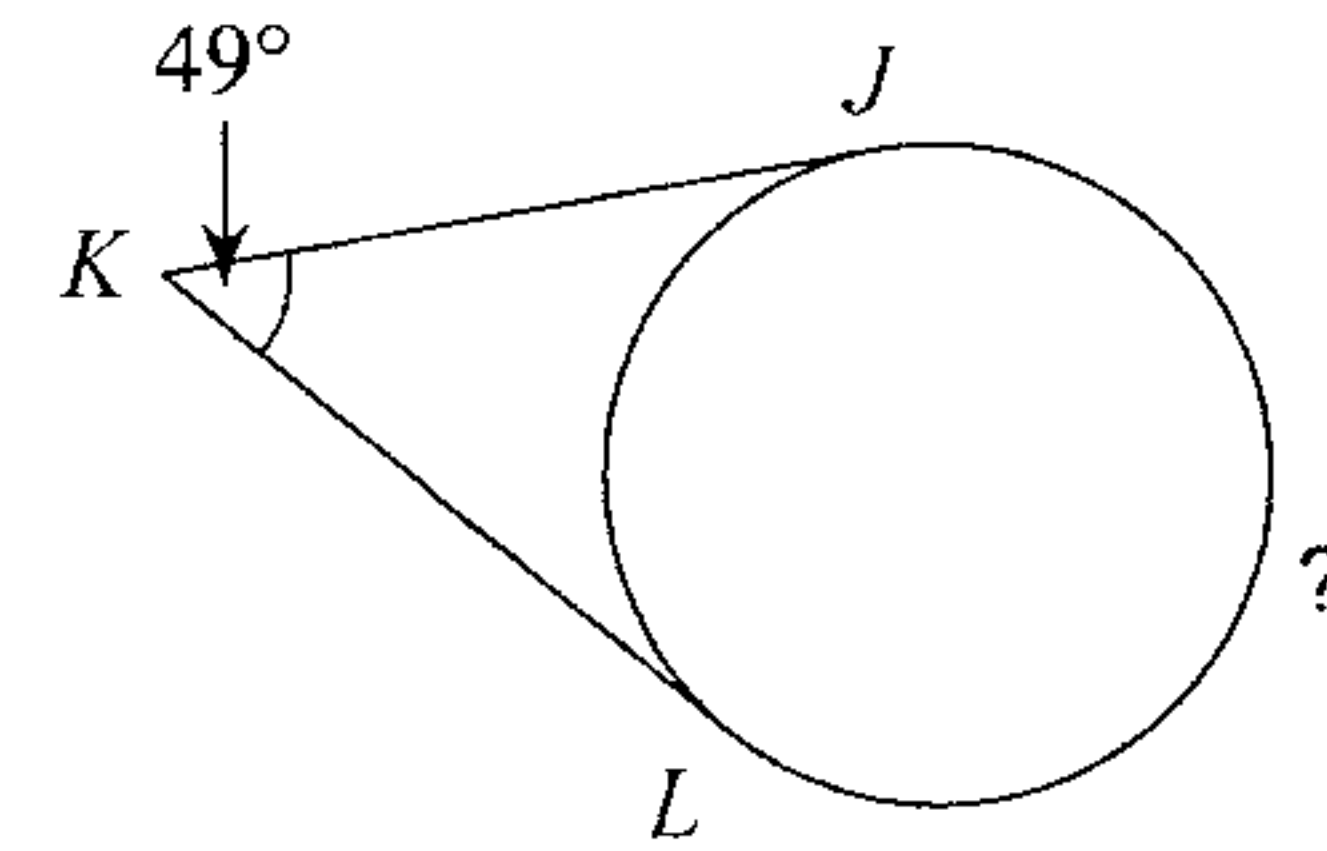

Solve for x . Assume that lines which appear tangent are tangent.

17)

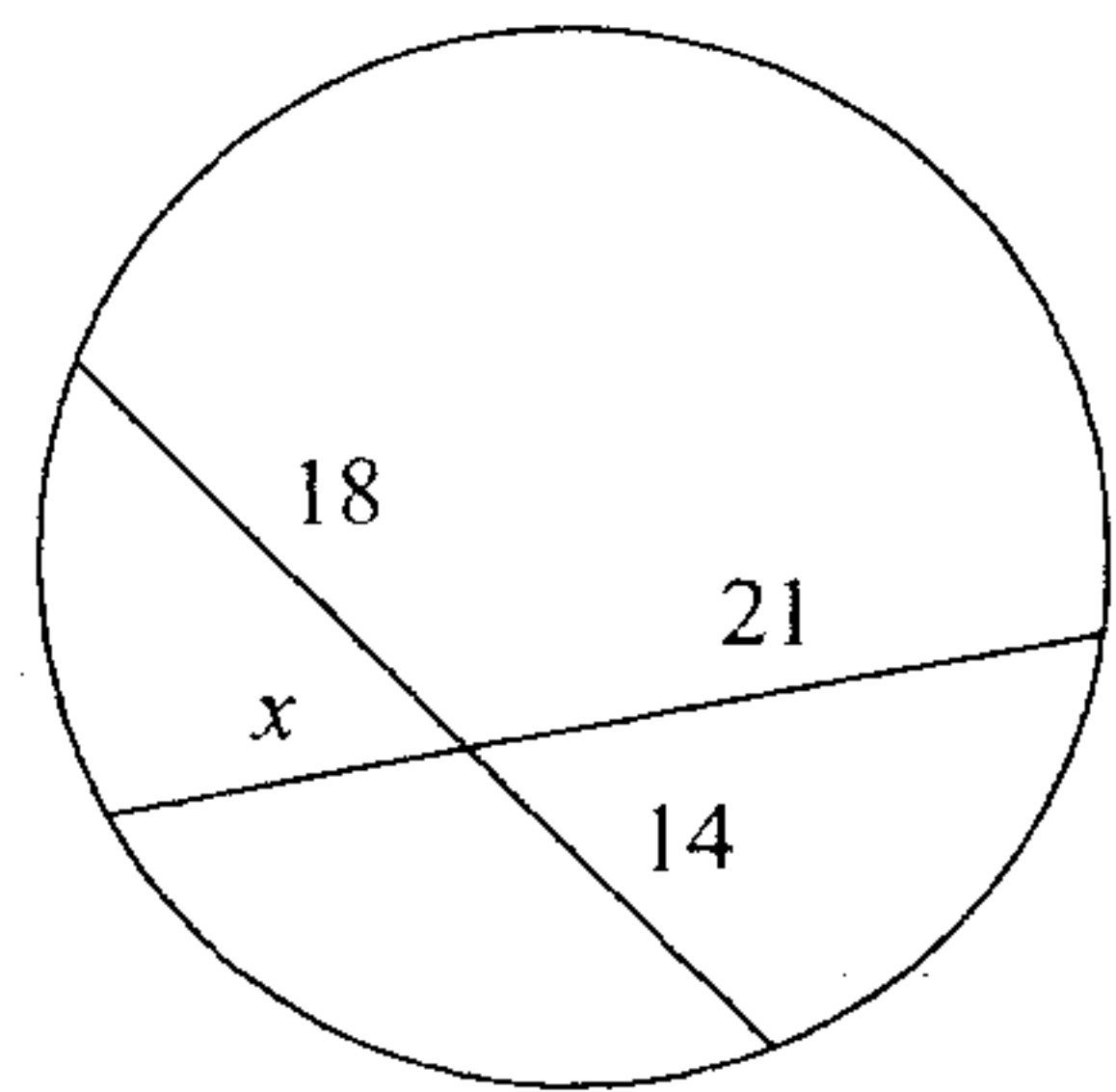

18)

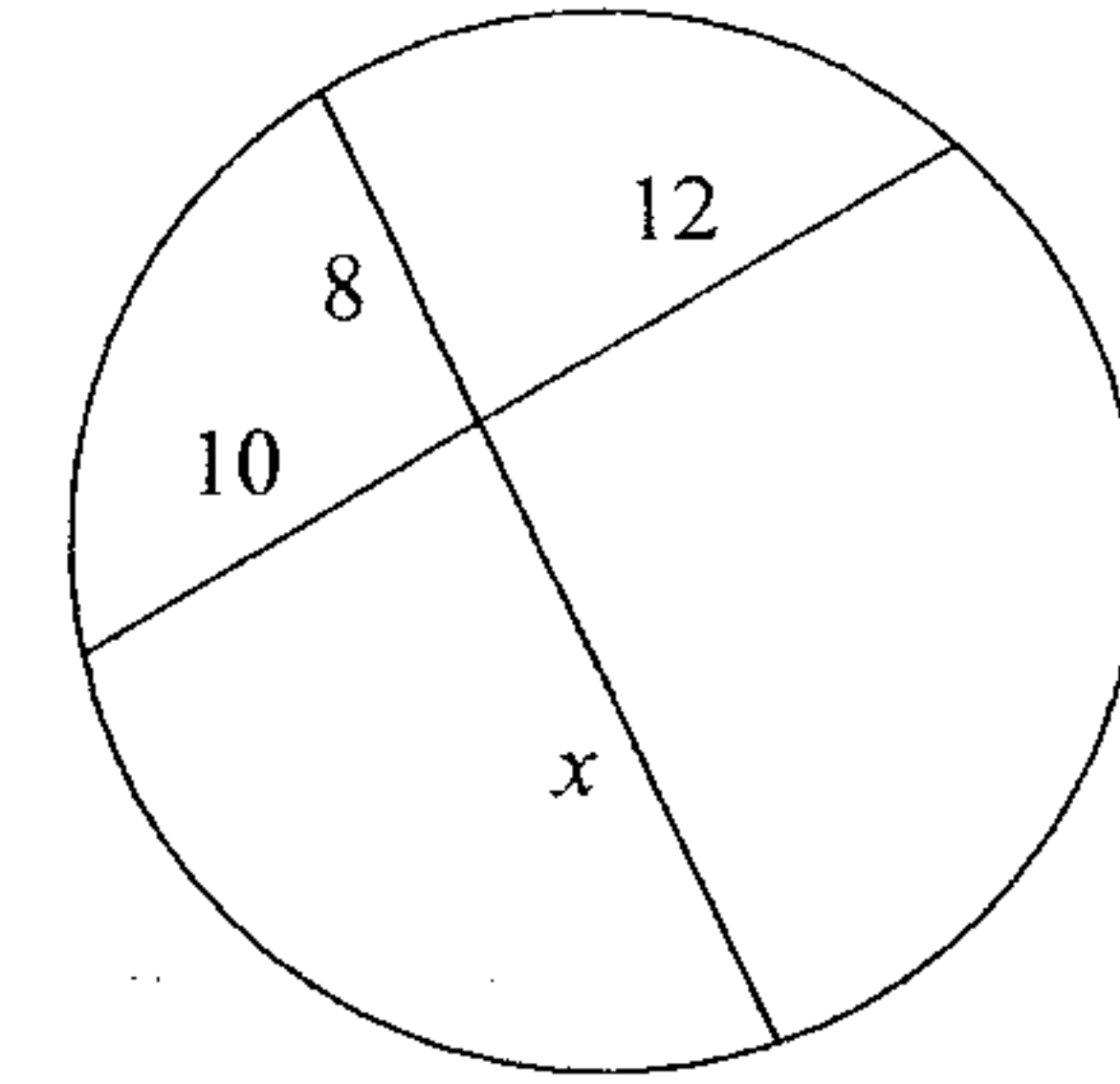

19)

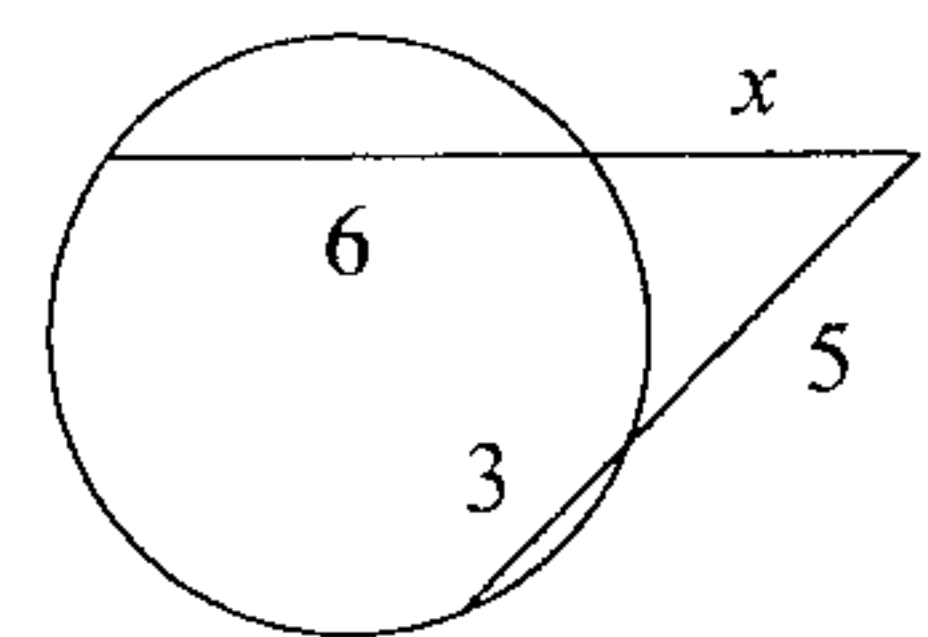

20)

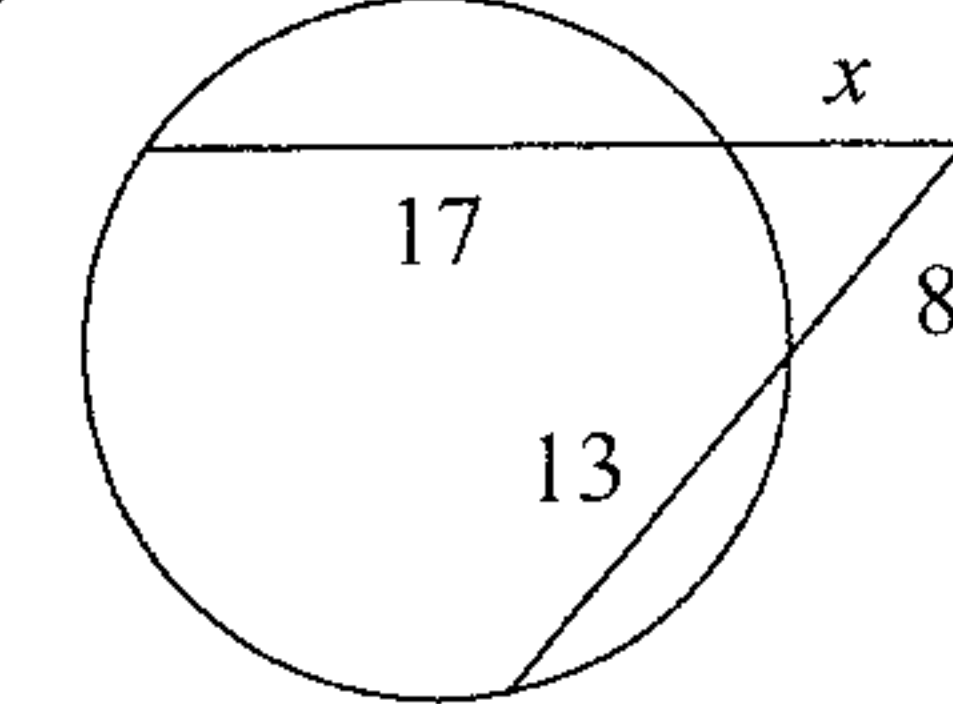

21)

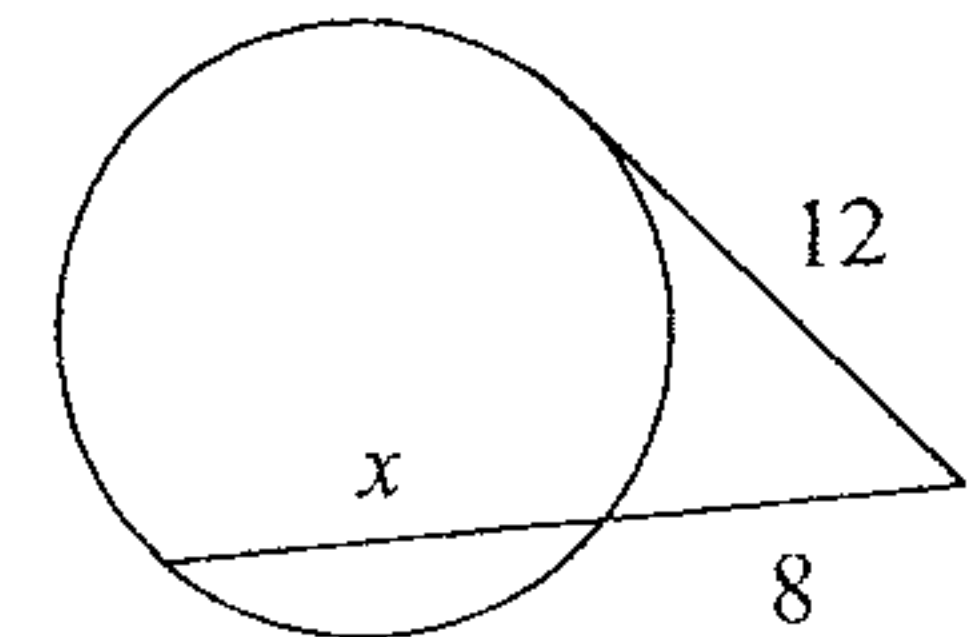

22)

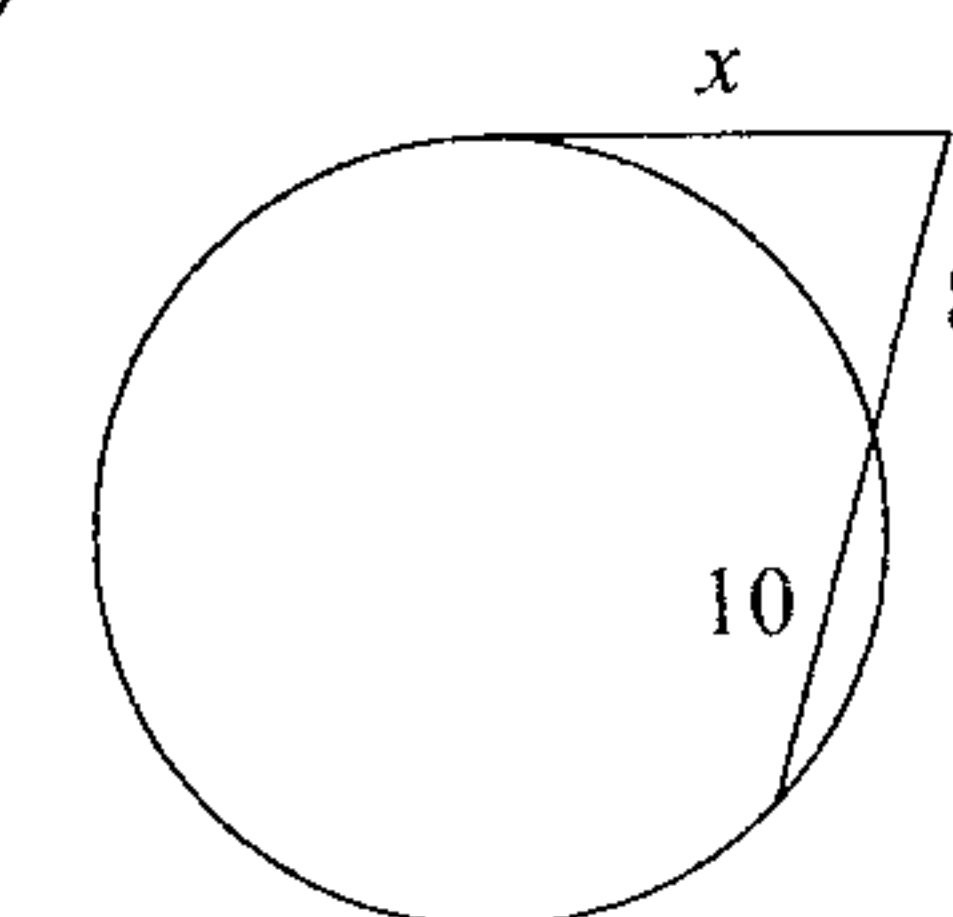

Find the area of each. Use your calculator's value of π . Round your answer to the nearest tenth.

23)

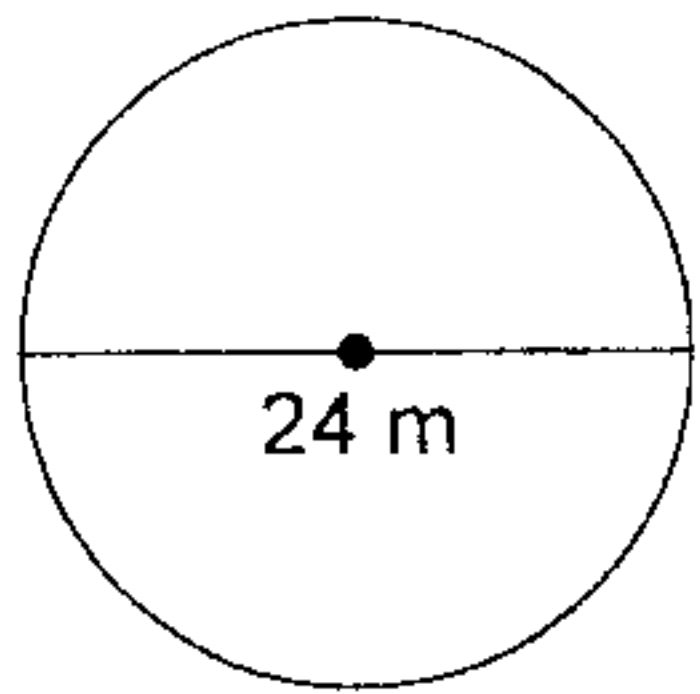

24)

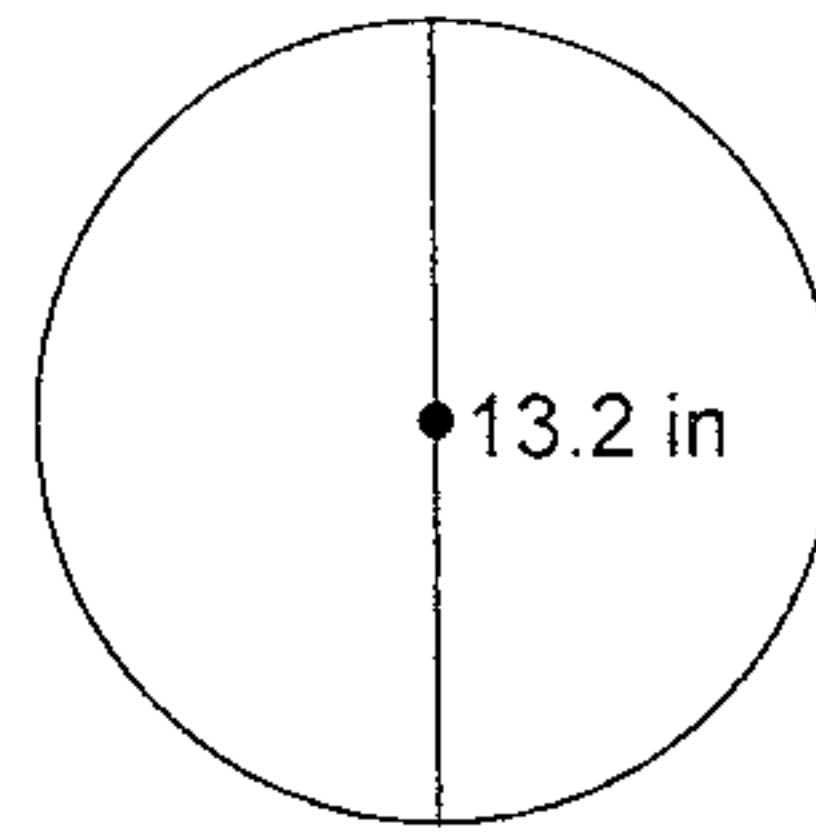

Find the circumference of each circle. Use your calculator's value of π . Round your answer to the nearest tenth.

25)

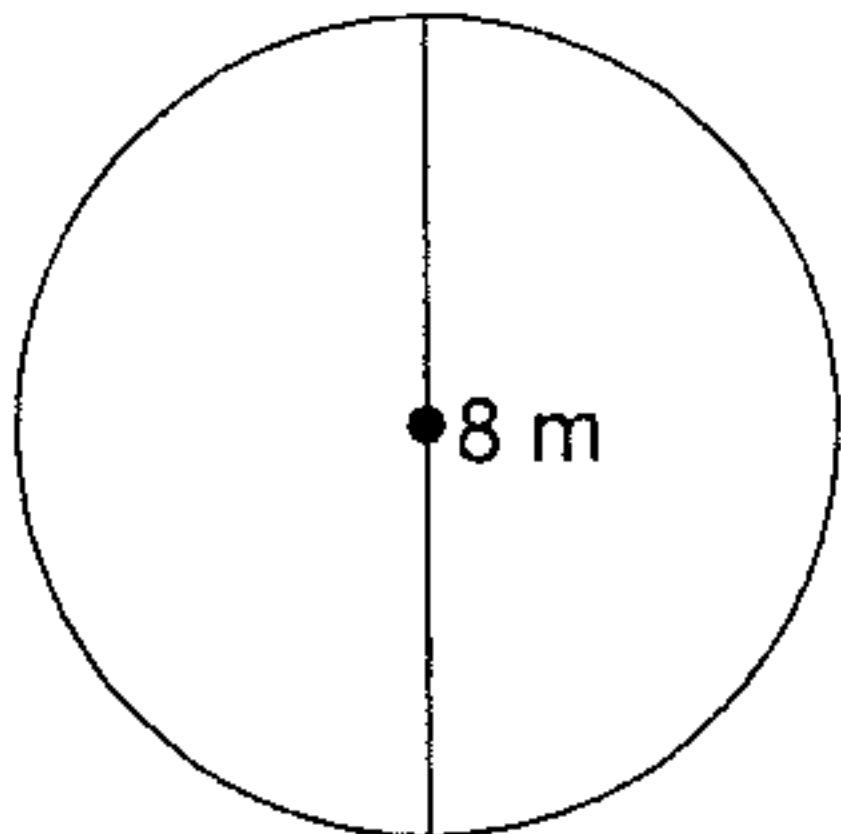

26)

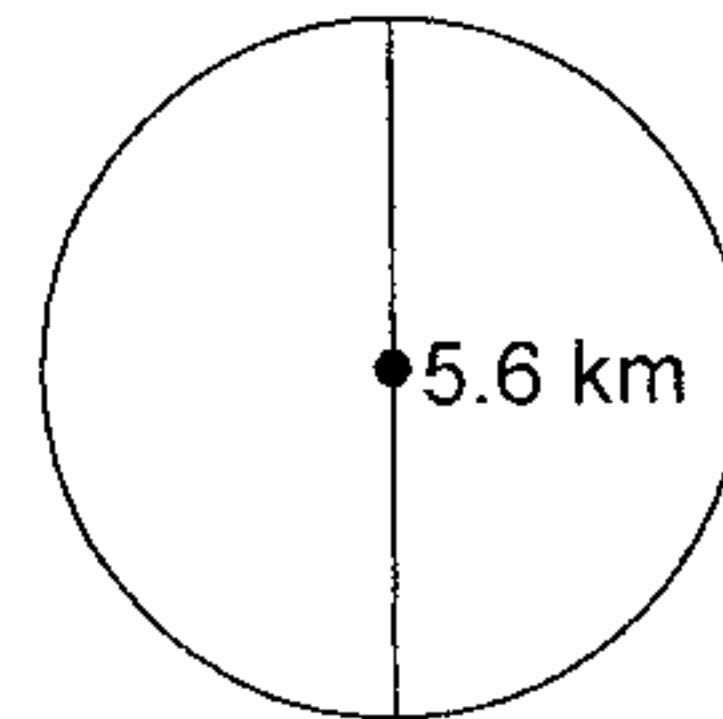

Find the radius of each circle. Use your calculator's value of π . Round your answer to the nearest tenth.

27) area = 113.1 m^2

28) area = 201.1 cm^2

Find the area of each. Use your calculator's value of π . Round your answer to the nearest tenth.

29)

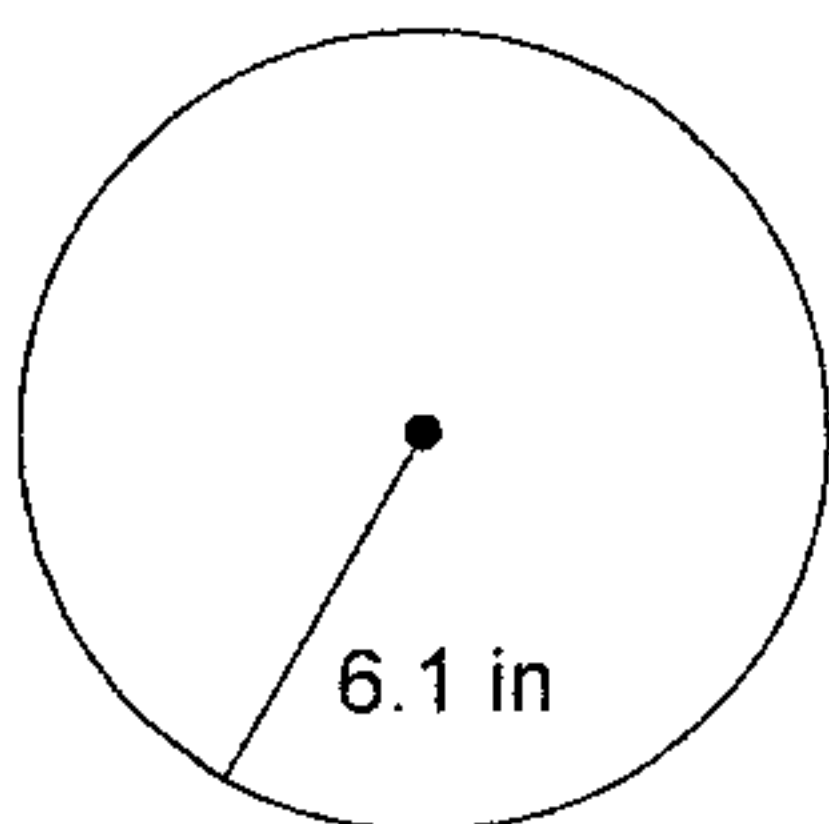

30)

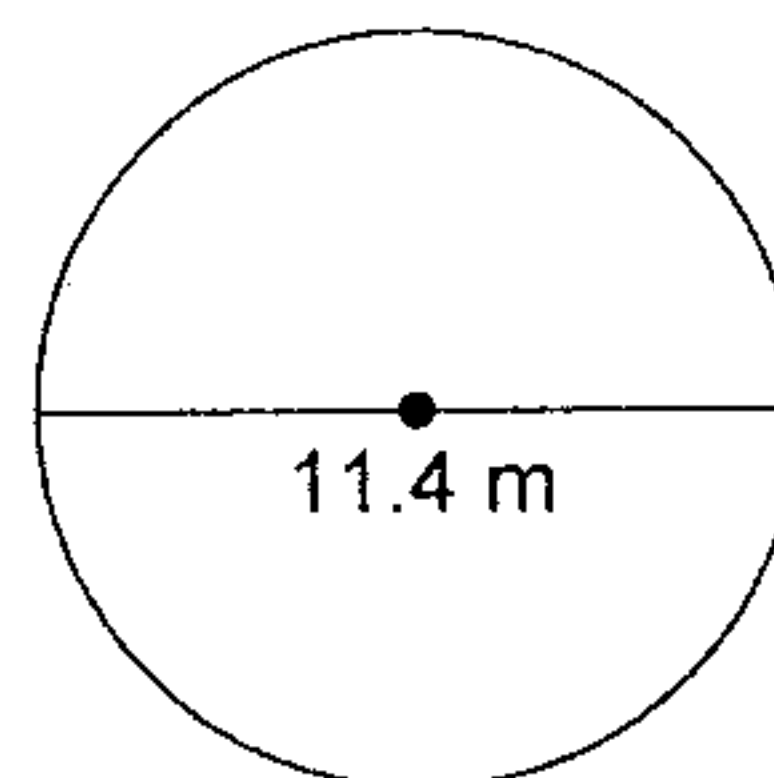

Find the radius of each circle. Use your calculator's value of π . Round your answer to the nearest tenth.

31) circumference = 69.1 cm

32) circumference = 75.4 mi

Find the length of each arc.

33)

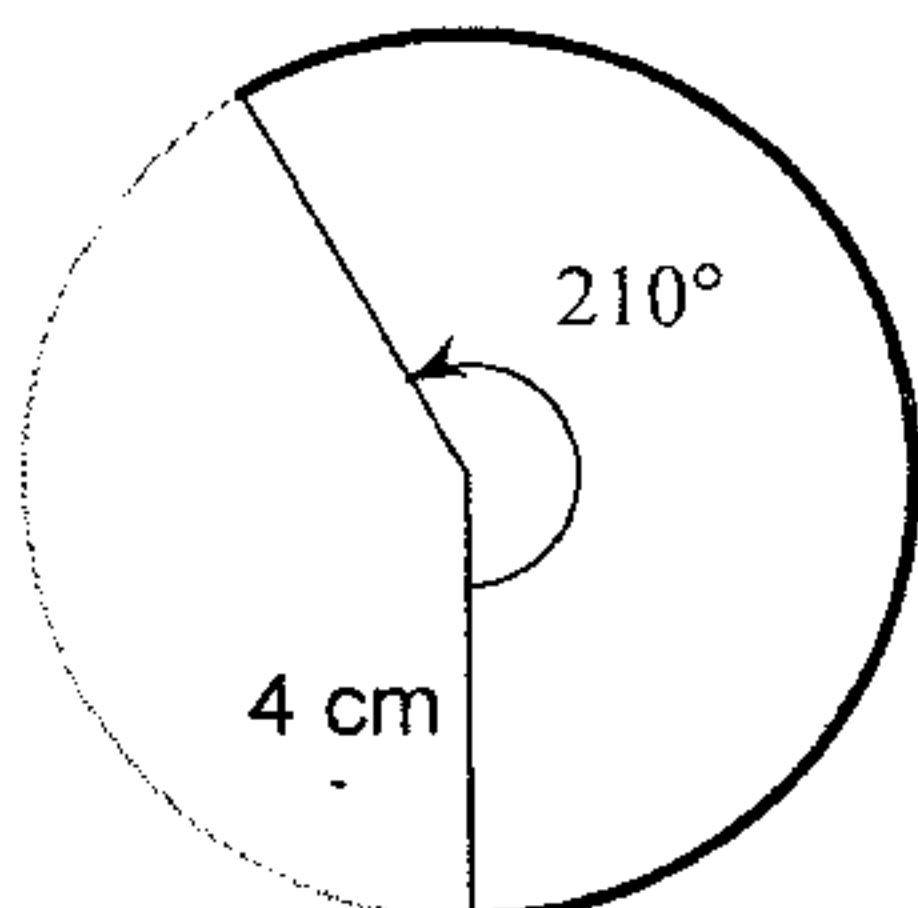

34)

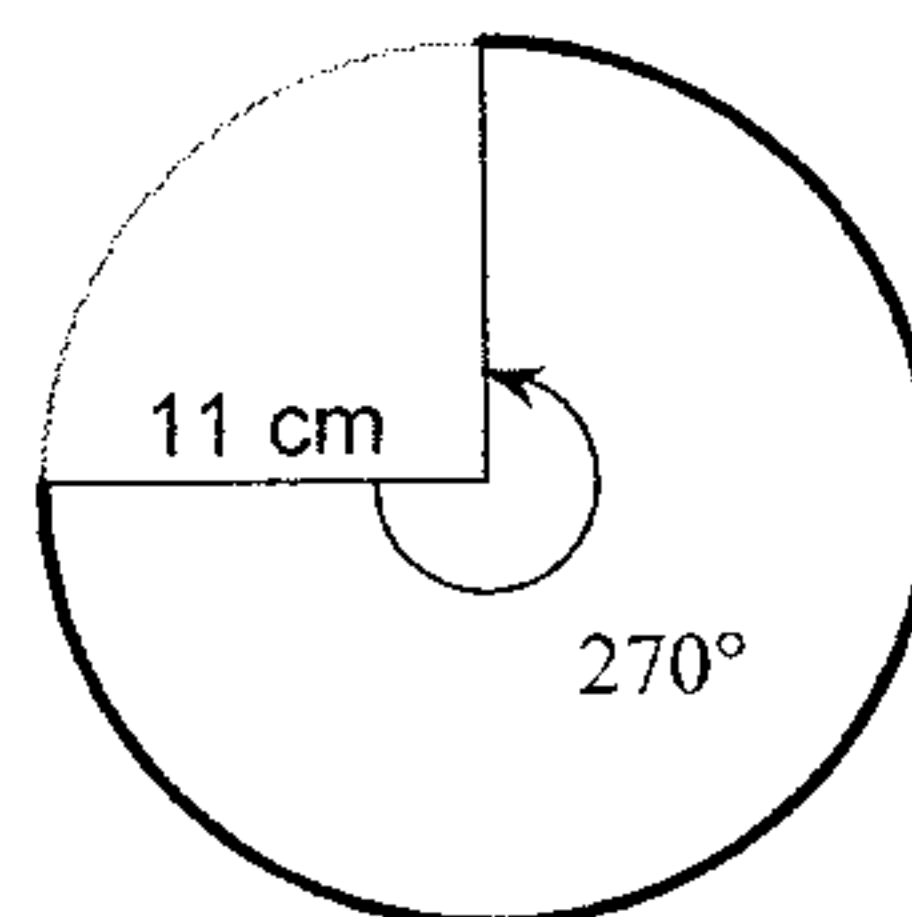

Find the area of each sector.

35)

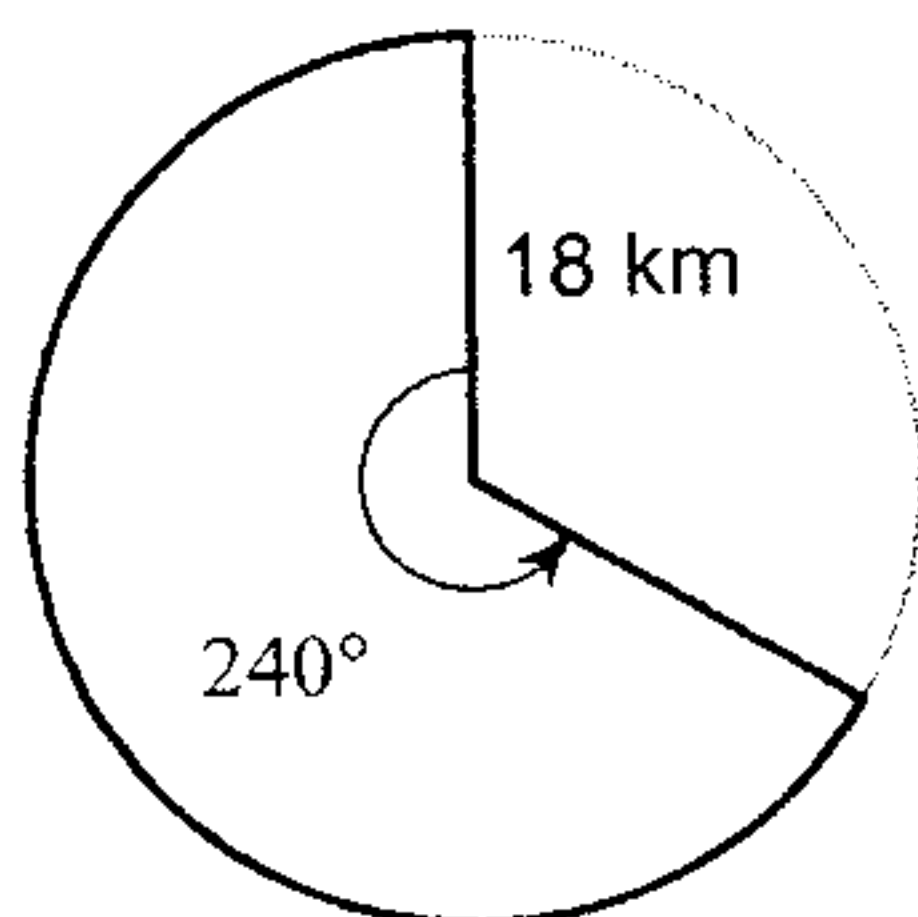

36)

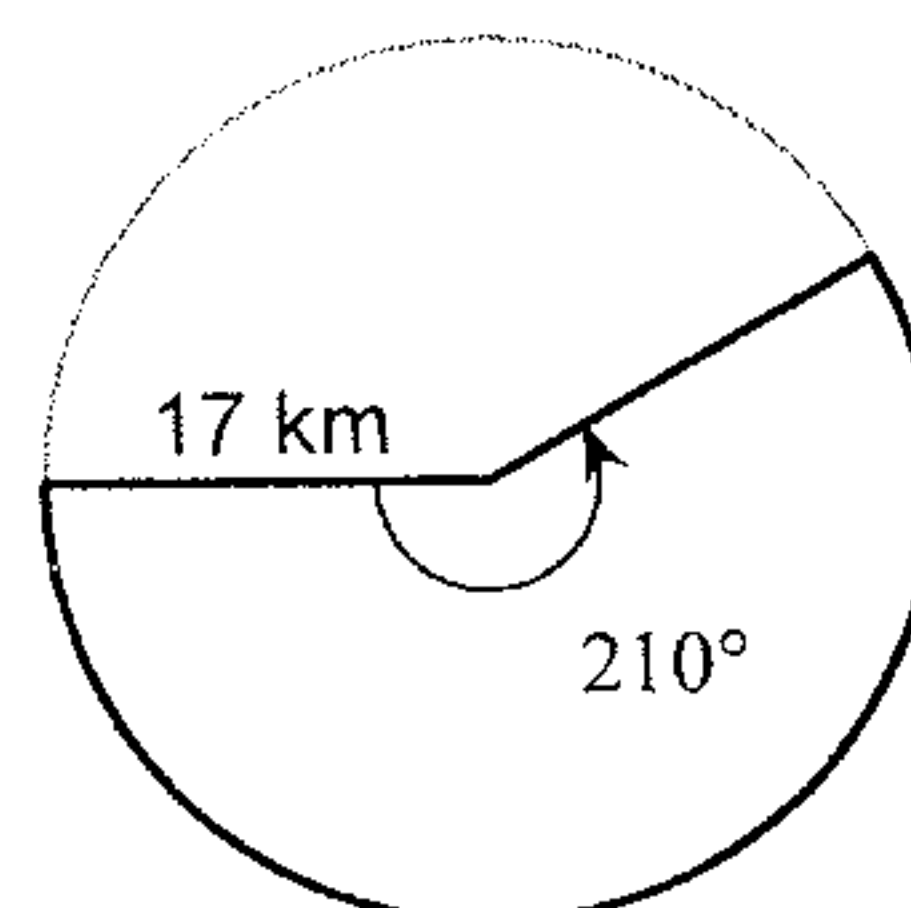

Answers to Circles (ID: 1)

1) 310°

5) $x = 12, y = 5$

9) 55°

13) 41°

17) 12

21) 10

25) 25.1 m

29) 116.9 in^2

33) $\frac{14\pi}{3} \text{ cm}$

2) 65°

6) $x = 0, y = 0$

10) 105°

14) 34°

18) 15

22) 12

26) 17.6 km

30) 102.1 m^2

34) $\frac{33\pi}{2} \text{ cm}$

3) 95°

7) 150°

11) 98°

15) 65°

19) 4

23) 452.4 m^2

27) 6 m

31) 11 cm

35) $216\pi \text{ km}^2$

4) 113°

8) 190°

12) 50°

16) 229°

20) 7

24) 136.8 in^2

28) 8 cm

32) 12 mi

36) $\frac{2023\pi}{12} \text{ km}^2$

Write the functions for the given graphs

31.

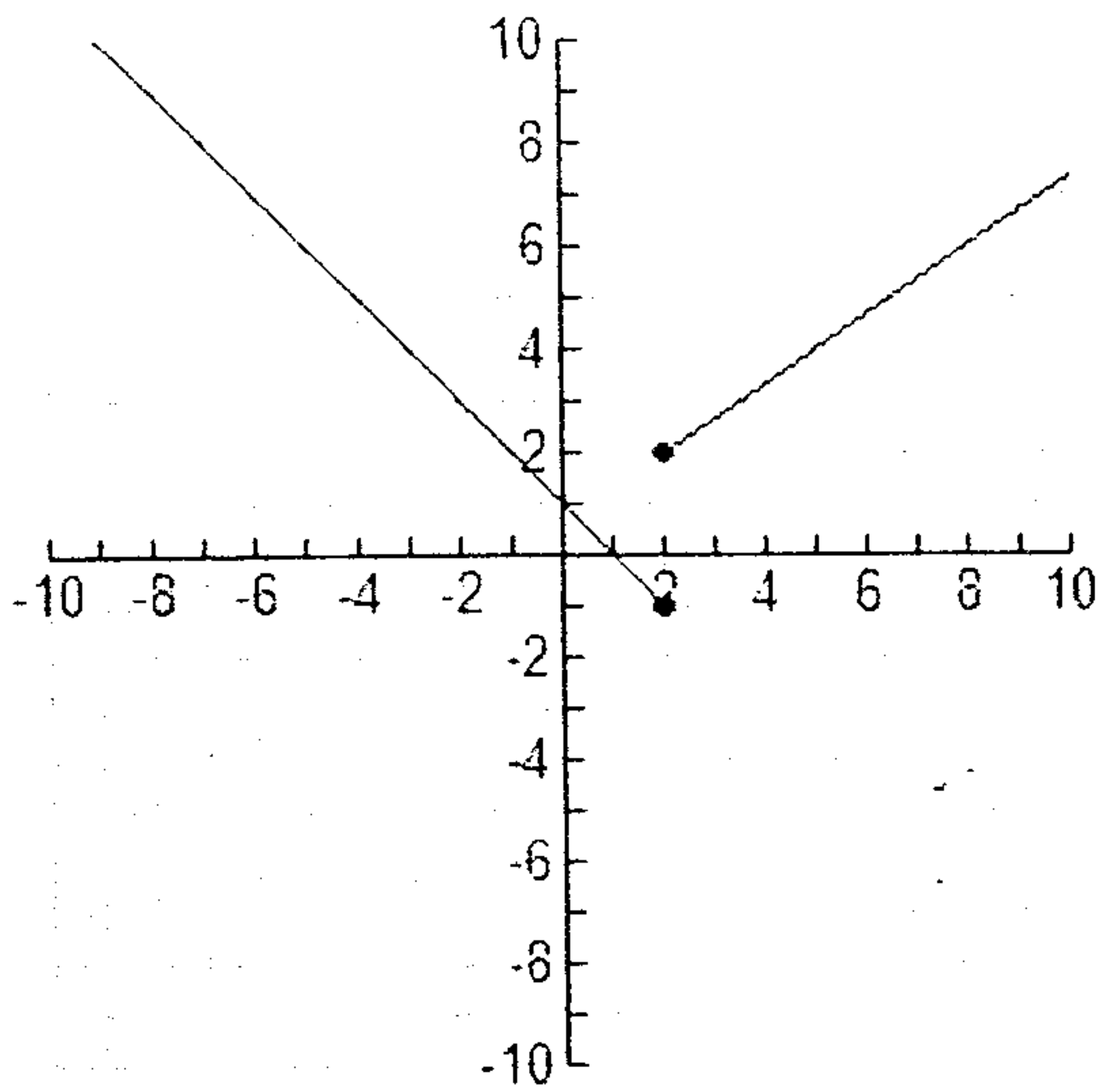

32.

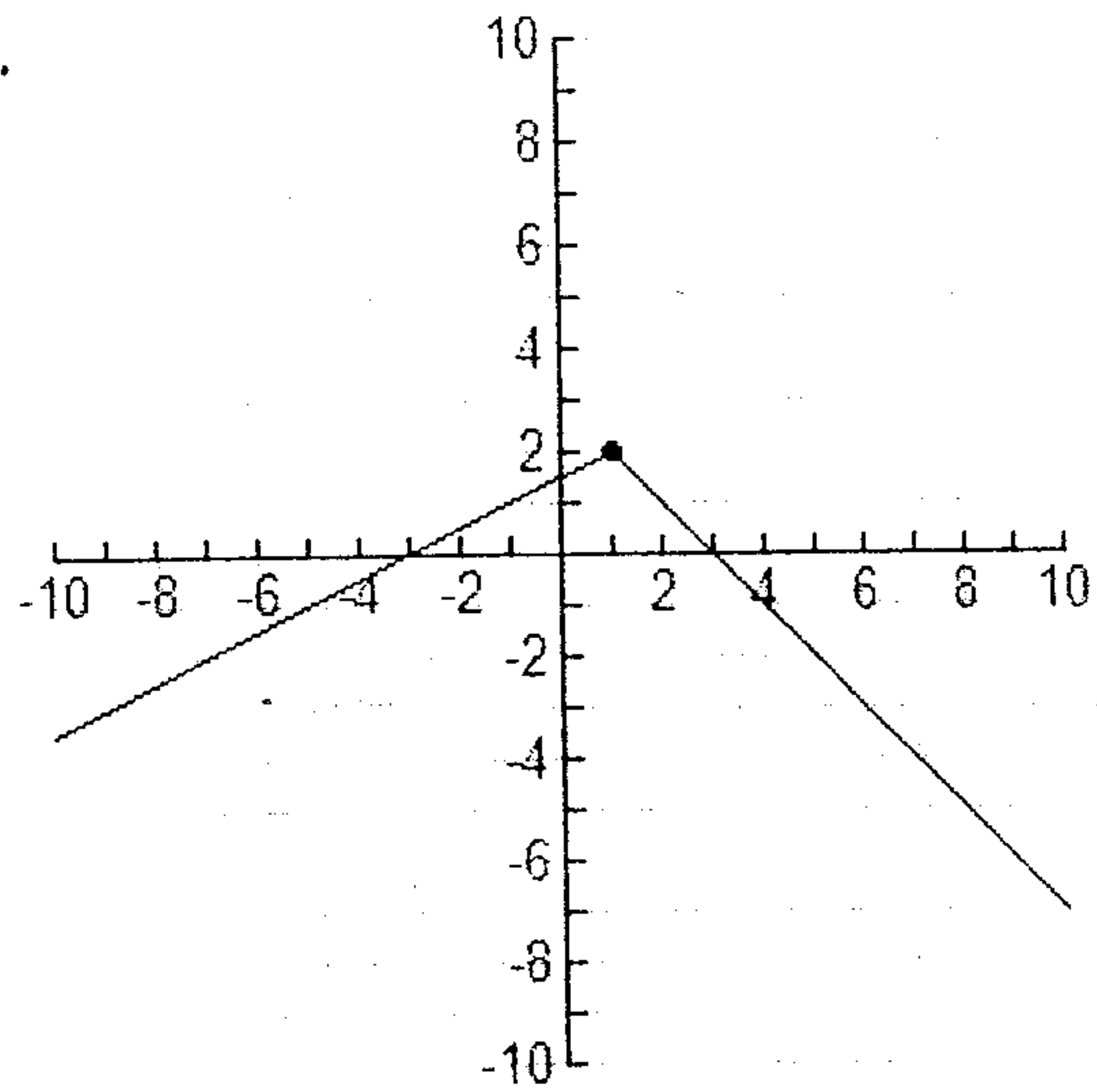

Graph the step function

33. $f(x) = \begin{cases} 1, & \text{when } -4 \leq x < -1 \\ 3, & \text{when } -1 \leq x < 2 \end{cases}$

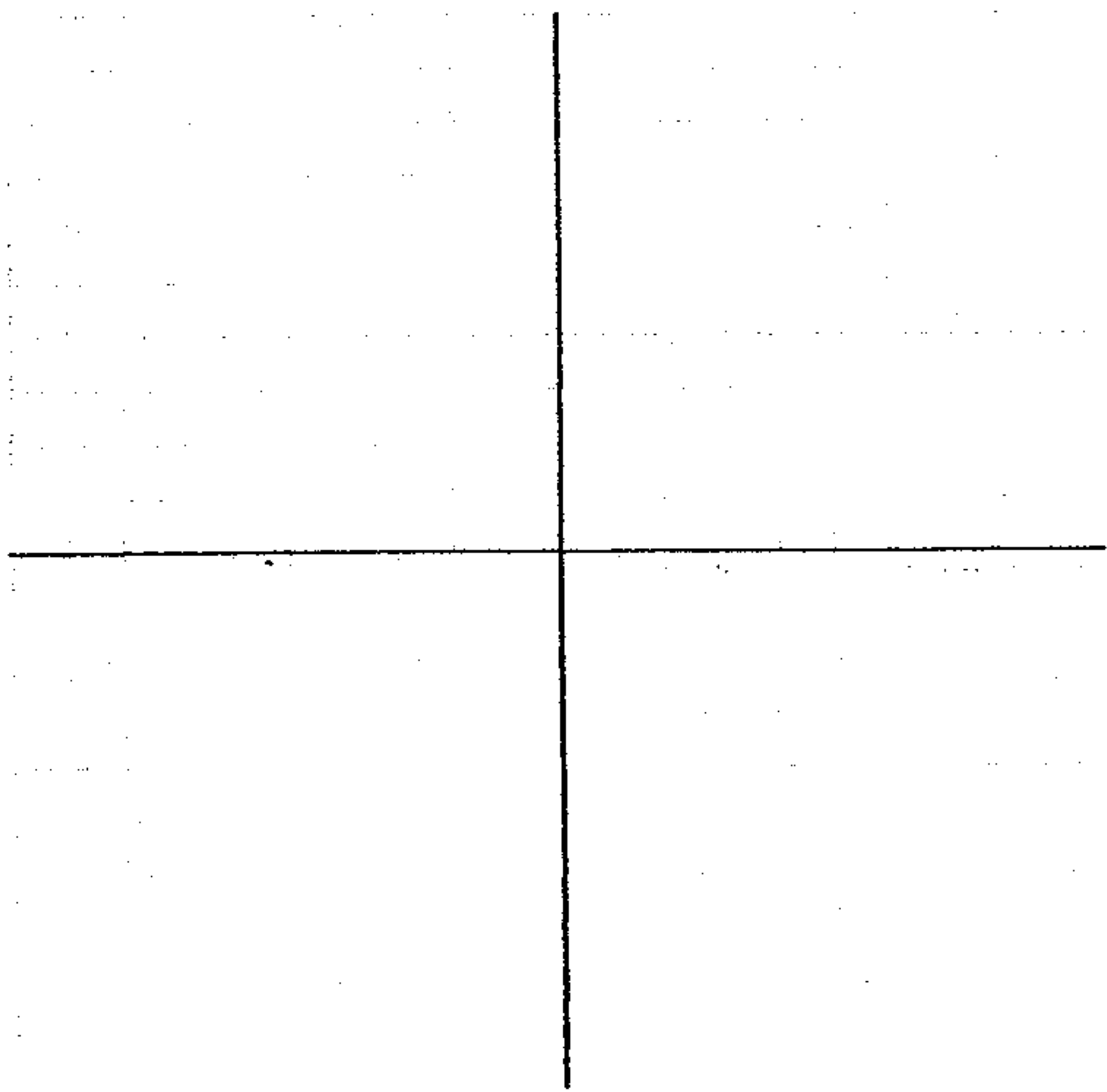

Write the step function

34.

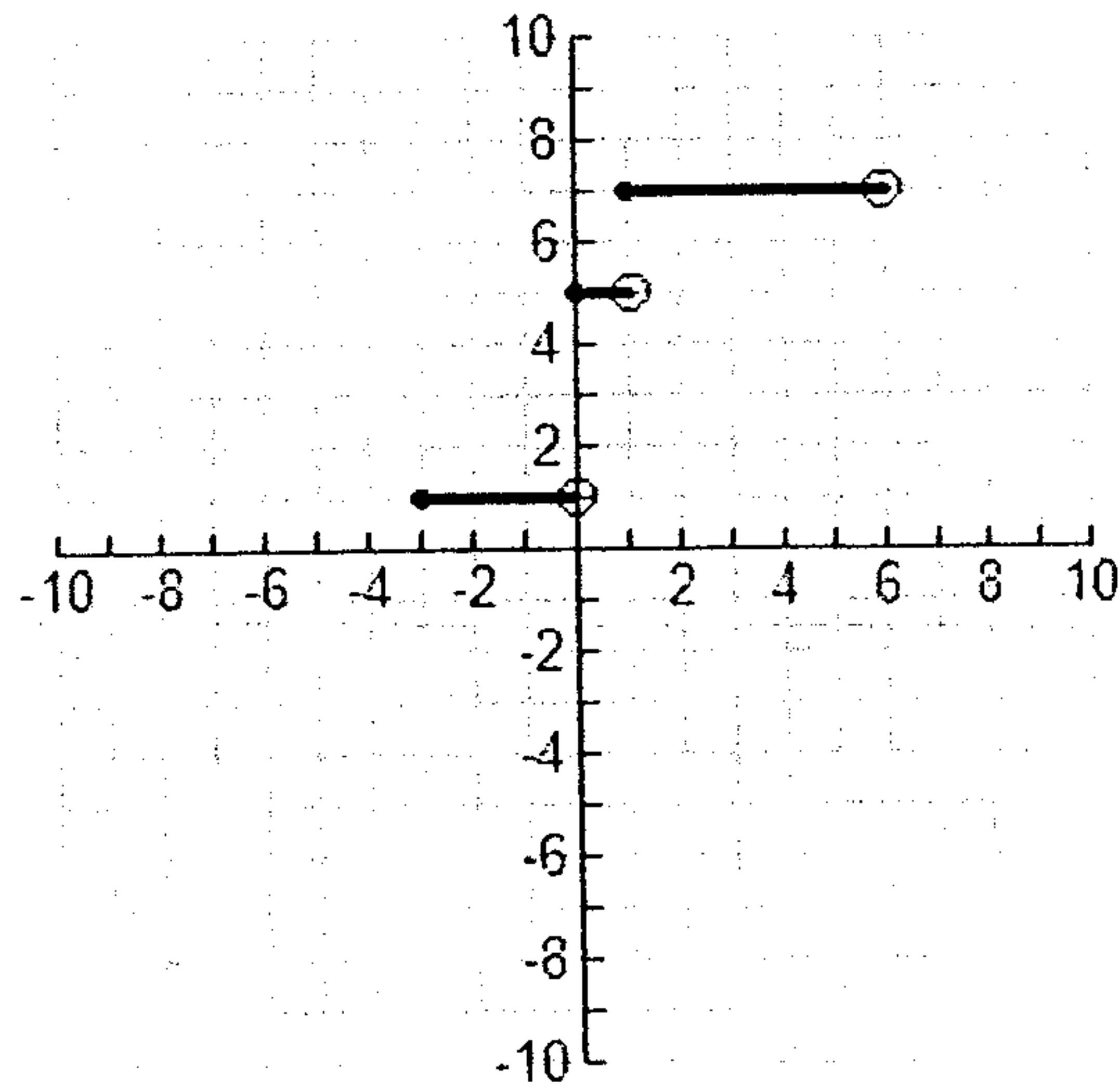

35.

You have a summer job that pays time and a half for overtime. That means, if you work more than 40 hours in a week, your hourly wage for the extra hours is 1.5 times your normal rate of \$7 per hour.

a. Write a piecewise function describing your weekly pay (P) in terms of the number of hours worked (h).

b. How much will you get paid if you work work 47 hours?

c. How much will you get paid if you work 30 hours?